



**Pre-Demolition Environmental Inspection Summary Report**

**Prepared For:**

**City of Royal Oak Township**

**18-023-149**

<b>Parcel Number:</b>	2533360002	<b>Inspected By:</b>
<b>Property Address:</b>	20868 Parkside Blvd. Ferndale, MI 48220	<b>J Wilhelmi</b> <b>September 25, 2018</b>



<b>STRUCTURE IN GOOD CONDITION</b>	<b>CATEGORY 1 &amp; 2 FRIABLE ACM PRESENT</b>
<b>COMPLETE BUILDING ACCESS</b>	<b>TIRES NOT PRESENT</b>

**BUILDING DATA**20868 Parkside Blvd.  
Ferndale, MI 48220

Number Of Stories	2 + Basement	Basement Walls	No Paint, Staining or Mastic
Year Built	Unknown	Basement Floors	No Paint, Staining or Mastic
Footprint Dimensions	20x30	Garage Walls	No Paint, Staining or Mastic
Square Footage	2,270	Garage Floors	No Paint, Staining or Mastic
Siding	Vinyl/Transite	Secured	Yes
Color	White	Occupied	No
Roof Material	Shingle		
Electric Service	No		
Gas Service	No		

**EXECUTIVE SUMMARY OF ACM**20868 Parkside Blvd.  
Ferndale, MI 48220

HA	SAMPLE NUMBERS	DESCRIPTION	LOCATION(S)	APPROXIMATE QUANTITIES	ACM	CAT	%
HA8	T 1A-B	Transite	FS Exterior	~1,500 SF	Chrysotile	CAT 2 NF	15 %
HA9	DI 1A-C	Duct Insulation	FS 9	~12 SF	Chrysotile	CAT 1	50 %
HA1	FT 1A-B	Floor Tile/Mastic	FS 2, 3, 8	~500 SF	NAD	CAT 2 NF	
HA2	FT 2A-B	Floor Tile/Mastic	FS 7	~70 SF	NAD	CAT 2 NF	
HA3	DW 1A-B	Drywall	FS 1-8	~4,000 SF	NAD	CAT 2 NF	
HA4	M 1A-B	Mortar	FS Exterior	~600 SF	NAD	CAT 2 NF	
HA5	WG 1A-G	Window Glaze	FS 9; Exterior	~3 SF; ~12 Windows	NAD	CAT 2 NF	
HA6	R 1A-B	Roofing	FS Exterior	~1,200 SF	NAD	CAT 2 NF	
HA7	S 1A-B	Siding Shingles	FS Exterior	~1,500 SF	NAD	CAT 2 NF	
HA10	PL 1A-C	Plaster	FS 1, 2	~900 SF	NAD	CAT 1	
HA11							

Lead-Based Paint (LBP) should be assumed to be present on the site and is a hazardous substance. Its condition is regulated by federal, state, and local agencies. LBP generally does not pose a health threat unless particles are disturbed and ingested. Contractors and their employers that will be disturbing the building during demolition should follow OSHA Lead in Construction Standard.

Further testing may be required of other regulated materials and/or debris generated from demolition activities to determine whether the other regulated materials and/or debris should be disposed as hazardous waste under the Resource Conservation and Recovery Act (RCRA) in accordance with 40-CFR Part 261 Subpart C.



**TABLE 1 ACM**

**20868 Parkside Blvd.  
Ferndale, MI 48220**



SAMPLE ID	DESCRIPTION	SAMPLE LOCATION	HA	ACM	%	MiOSHA CLASS	DEQ CATEGORY
FT 1A	Floor Tile/Mastic	FS 3	HA1	NAD		CLASS 2 NON FRI	CAT 2 NON FRI
FT 1B	Floor Tile/Mastic	FS 3	HA1	NAD		CLASS 2 NON FRI	CAT 2 NON FRI
FT 2A	Floor Tile/Mastic	FS 7	HA2	NAD		CLASS 2 NON FRI	CAT 2 NON FRI
FT 2B	Floor Tile/Mastic	FS 7	HA2	NAD		CLASS 2 NON FRI	CAT 2 NON FRI
DW 1A	Drywall	FS 1	HA3	NAD		CLASS 2 NON FRI	CAT 2 NON FRI
DW 1B	Drywall	FS 2	HA3	NAD		CLASS 2 NON FRI	CAT 2 NON FRI
M 1A	Mortar	FS Exterior	HA4	NAD		CLASS 2 NON FRI	CAT 2 NON FRI
M 1B	Mortar	FS Exterior	HA4	NAD		CLASS 2 NON FRI	CAT 2 NON FRI
WG 1A	Window Glaze	FS 9	HA5	NAD		CLASS 2 NON FRI	CAT 2 NON FRI
WG 1B	Window Glaze	FS Exterior	HA5	NAD		CLASS 2 NON FRI	CAT 2 NON FRI
R 1A	Roofing	FS Exterior	HA6	NAD		CLASS 2 NON FRI	CAT 2 NON FRI
R 1B	Roofing	FS Exterior	HA6	NAD		CLASS 2 NON FRI	CAT 2 NON FRI
S 1A	Siding Shingles	FS Exterior	HA7	NAD		CLASS 2 NON FRI	CAT 2 NON FRI
S 1B	Siding Shingles	FS Exterior	HA7	NAD		CLASS 2 NON FRI	CAT 2 NON FRI
<b>T 1A</b>	<b>Transite</b>	<b>FS Exterior</b>	<b>HA8</b>	<b>Chrysotile</b>	<b>15 %</b>	<b>CLASS 2 NON FRI</b>	<b>CAT 2 NON FRI</b>
<b>T 1B</b>	<b>Transite</b>	<b>FS Exterior</b>	<b>HA8</b>	<b>NOT ANALYZED</b>		<b>CLASS 2 NON FRI</b>	<b>CAT 2 NON FRI</b>
<b>DI 1A</b>	<b>Duct Insulation</b>	<b>FS 9</b>	<b>HA9</b>	<b>Chrysotile</b>	<b>50 %</b>	<b>CLASS 1 FRI</b>	<b>FRIABLE</b>
<b>DI 1B</b>	<b>Duct Insulation</b>	<b>FS 9</b>	<b>HA9</b>	<b>NOT ANALYZED</b>		<b>CLASS 1 FRI</b>	<b>FRIABLE</b>
<b>DI 1C</b>	<b>Duct Insulation</b>	<b>FS 9</b>	<b>HA9</b>	<b>NOT ANALYZED</b>		<b>CLASS 1 FRI</b>	<b>FRIABLE</b>
PL 1A	Plaster	FS 2	HA10	NAD		CLASS 1 FRI	FRIABLE
PL 1B	Plaster	FS 1	HA10	NAD		CLASS 1 FRI	FRIABLE
PL 1C	Plaster	FS 2	HA10	NAD		CLASS 1 FRI	FRIABLE



Key: F = Friable; NF = Non-friable; FS = Functional Space; HA = Homogeneous Area, NAD = No Asbestos Detected;  
SF = Square Feet; LF = Linear Feet; CF = Cubic Feet; MF = Mud Fittings; Classification: SM = Surfacing Material; TSI = Thermal System Insulation; MM =  
Miscellaneous Material; EPA Material Categories: FR = Friable Regulated;  
C2 = Category II Non-friable; C1 = Category I Non-friable; NE = Not Estimated

NOTE: \*Results listed in this report reflect the site conditions encountered at the time of the inspection. JACX Group, LLC make no warrentee, express or  
implied that conditions encountered during demolition or abatement will be the same. \*\* Care was taken to access, inspect, and sample all suspect  
materials encountered on the site. If undiscovered material is encountered it is the responsibility of the contractor to contact JACX Group, LLC for further  
testing and quantification. \*\*\*For supplemental testing please contact JACX Group, LLC. Composites and Point

Counts taken by a demolition contractor, abatement contractor, or building inspector renders this Pre Demolition Survey VOID for use as an  
OSHA/NESHAP document for the purposes of demolition or abatement.



- 1 DRAWINGS
- 2 LABORATORY DATA
- 3 REGULATORY INFORMATION
- 4 SAMPLING METHODS

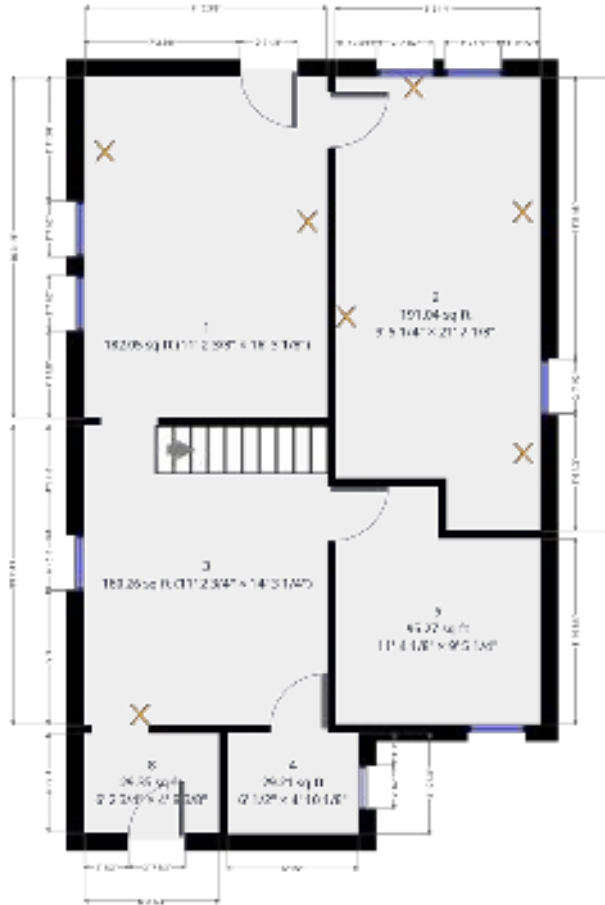

EVERYBODY'S RIGHTS WITHOUT REGARD TO SEX, RACE, COLOR, NATIONAL ORIGIN, RELIGION, OR ANCESTRY, ETHNICITY, OR GENETIC INFORMATION. FOR MORE INFORMATION, SEE JACO PRESS, 49630 Au Lac Drive East Chesterfield, MI 48019. CONTACT: 586-246-0725. WWW.JACOPRESS.COM



# 20868 Parkside

20868 Parkside Blvd, Ferndale, MI 48220, USA, Ferndale, Michigan, United States 48220

**John Wilhelmi**

jwilhelmi.enviro@gmail.com

8103369197



## Statistics

Area: 1807 sq ft

3 Floors

3 Bedrooms

2 Bathrooms



## Basement

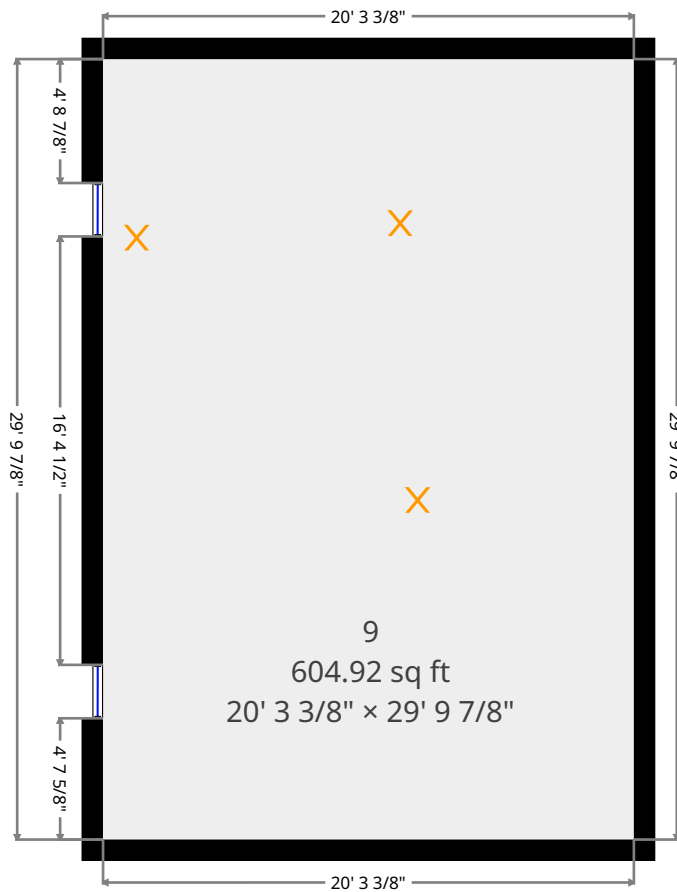

THIS FLOORPLAN IS PROVIDED WITHOUT WARRANTY OF ANY KIND. CENTRAL INDUSTRIAL ASBESTOS LLC DISCLAIMS ANY WARRANTY INCLUDING, WITHOUT LIMITATION, SATISFACTORY QUALITY OR ACCURACY OF DIMENSIONS. INACCURACIES ARE TO BE REPORTED TO CIA PRIOR TO ACTION. CIA MAKES NO WARRANTY IF USE...



# 20868 Parkside

20868 Parkside Blvd, Ferndale, MI 48220, USA, Ferndale, Michigan, United States 48220

John Wilhelmi  
jwilhelmi.enviro@gmail.com  
8103369197

9

Width: 20' 3 3/8"  
Length: 29' 9 7/8"  
Area: 604.92 sq ft  
Perimeter: 100' 2 1/2"

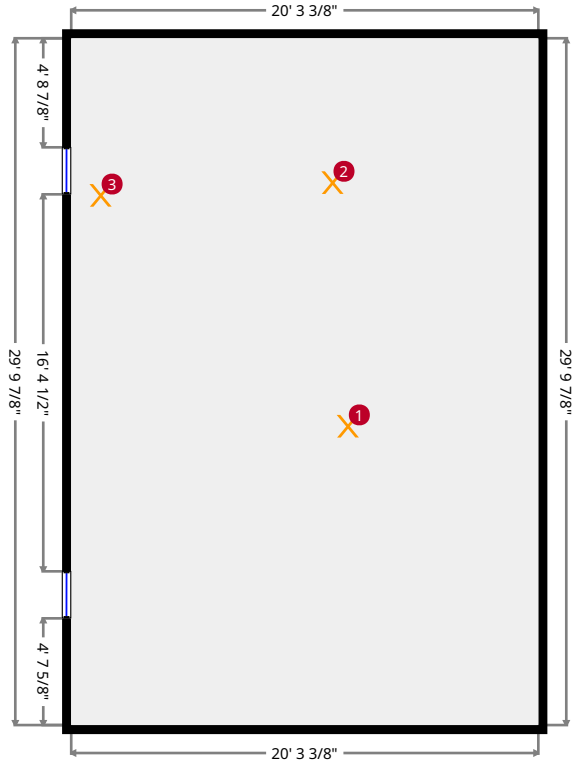
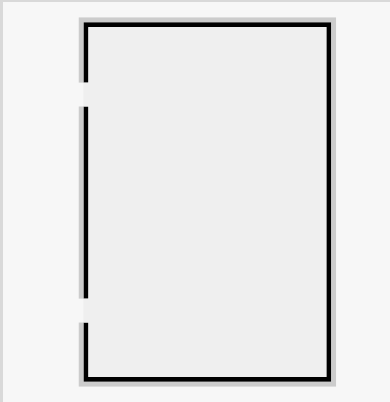

THIS FLOORPLAN IS PROVIDED WITHOUT WARRANTY OF ANY KIND. CENTRAL INDUSTRIAL ASBESTOS LLC DISCLAIMS ANY WARRANTY INCLUDING, WITHOUT LIMITATION, SATISFACTORY QUALITY OR ACCURACY OF DIMENSIONS. INACCURACIES ARE TO BE REPORTED TO CIA PRIOR TO ACTION. CIA MAKES NO WARRANTEE IF USE...



# 20868 Parkside

20868 Parkside Blvd, Ferndale, MI 48220, USA, Ferndale, Michigan, United States 48220

**John Wilhelmi**  
jwilhelmi.enviro@gmail.com  
8103369197

- 
- 1  SUSPECT MATERIAM PLM SAMPLE  
di1a



- 
- 2  SUSPECT MATERIAM PLM SAMPLE  
dw1b c



- 
- 3  SUSPECT MATERIAM PLM SAMPLE  
wg1a





# 20868 Parkside

20868 Parkside Blvd, Ferndale, MI 48220, USA, Ferndale, Michigan, United States 48220

John Wilhelmi

jwilhelmi.enviro@gmail.com

8103369197



## Statistics

Area: 1807 sq ft

3 Floors

3 Bedrooms

2 Bathrooms



## Ground Floor

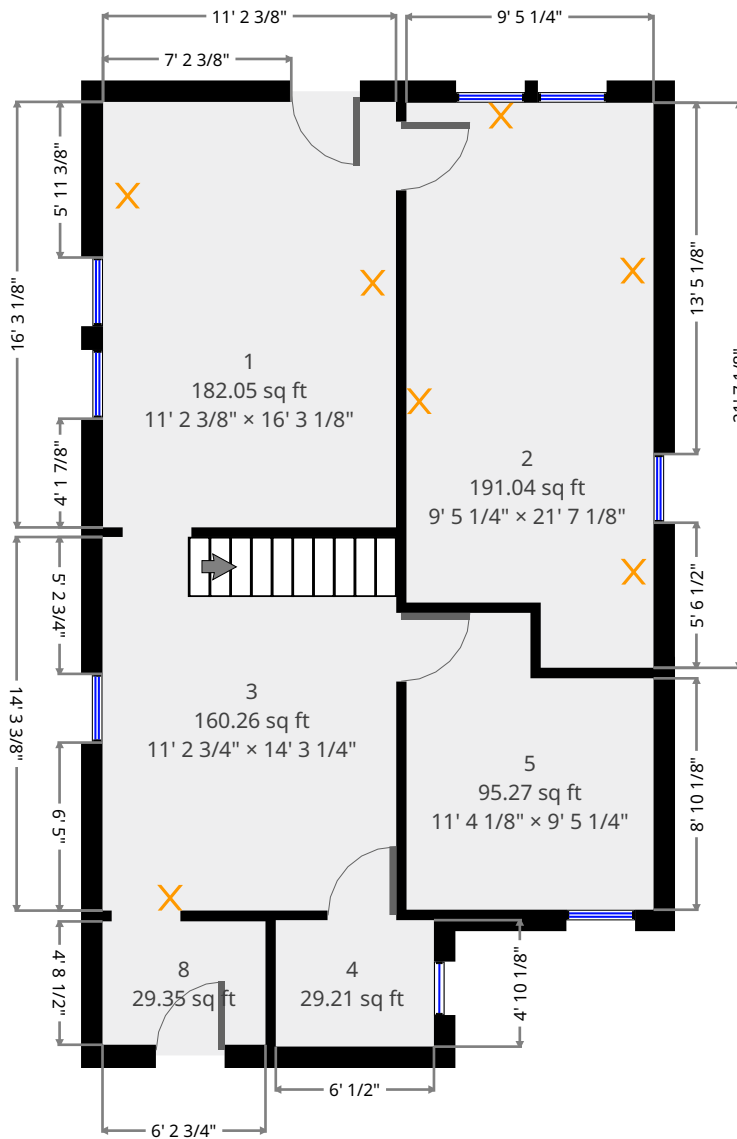

THIS FLOORPLAN IS PROVIDED WITHOUT WARRANTY OF ANY KIND. CENTRAL INDUSTRIAL ASBESTOS LLC DISCLAIMS ANY WARRANTY INCLUDING, WITHOUT LIMITATION, SATISFACTORY QUALITY OR ACCURACY OF DIMENSIONS. INACCURACIES ARE TO BE REPORTED TO CIA PRIOR TO ACTION. CIA MAKES NO WARRANTY IF USE...



# 20868 Parkside

20868 Parkside Blvd, Ferndale, MI 48220, USA, Ferndale, Michigan, United States 48220

John Wilhelmi  
jwilhelmi.enviro@gmail.com  
8103369197

1

Width: 11' 2 3/8"  
Length: 16' 3 1/8"  
Area: 182.05 sq ft  
Perimeter: 54' 11"

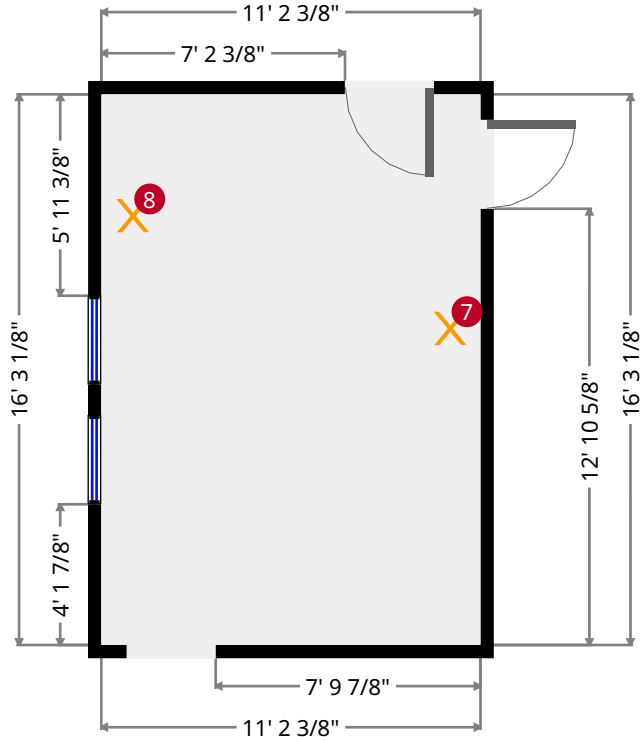
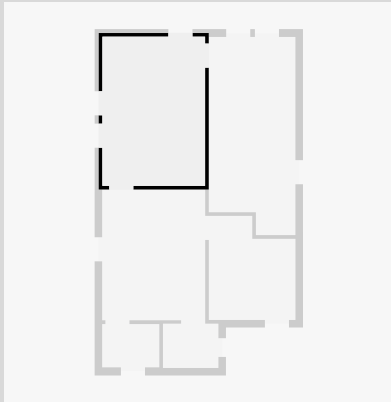

THIS FLOORPLAN IS PROVIDED WITHOUT WARRANTY OF ANY KIND. CENTRAL INDUSTRIAL ASBESTOS LLC DISCLAIMS ANY WARRANTY INCLUDING, WITHOUT LIMITATION, SATISFACTORY QUALITY OR ACCURACY OF DIMENSIONS. INACCURACIES ARE TO BE REPORTED TO CIA PRIOR TO ACTION. CIA MAKES NO WARRANTY IF USE...

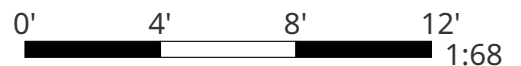

# 20868 Parkside

20868 Parkside Blvd, Ferndale, MI 48220, USA, Ferndale, Michigan, United States 48220

**John Wilhelmi**  
jwilhelmi.enviro@gmail.com  
8103369197

7



SUSPECT MATERIAM PLM SAMPLE

dw1a



8



SUSPECT MATERIAM PLM SAMPLE

pl1b



# 20868 Parkside

20868 Parkside Blvd, Ferndale, MI 48220, USA, Ferndale, Michigan, United States 48220

**John Wilhelmi**  
jwilhelmi.enviro@gmail.com  
8103369197

2

Width: 9' 5 1/4"  
Length: 21' 7 1/8"  
Area: 191.04 sq ft  
Perimeter: 62' 3/4"

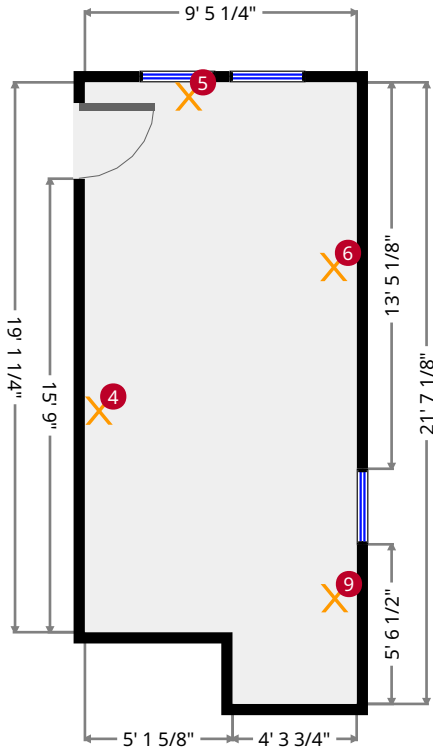
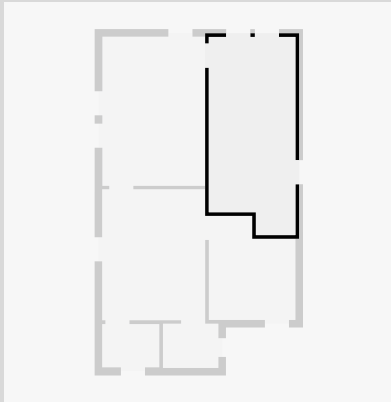

THIS FLOORPLAN IS PROVIDED WITHOUT WARRANTY OF ANY KIND. CENTRAL INDUSTRIAL ASBESTOS LLC DISCLAIMS ANY WARRANTY INCLUDING, WITHOUT LIMITATION, SATISFACTORY QUALITY OR ACCURACY OF DIMENSIONS. INACCURACIES ARE TO BE REPORTED TO CIA PRIOR TO ACTION. CIA MAKES NO WARRANTY IF USE...

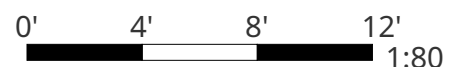

# 20868 Parkside

20868 Parkside Blvd, Ferndale, MI 48220, USA, Ferndale, Michigan, United States 48220

**John Wilhelmi**  
jwilhelmi.enviro@gmail.com  
8103369197

4



SUSPECT MATERIAM PLM SAMPLE  
dw1b



5



SUSPECT MATERIAM PLM SAMPLE  
wg1b



6



SUSPECT MATERIAM PLM SAMPLE  
pl1a



# 20868 Parkside

20868 Parkside Blvd, Ferndale, MI 48220, USA, Ferndale, Michigan, United States 48220

**John Wilhelmi**

jwilhelmi.enviro@gmail.com

8103369197

9



SUSPECT MATERIAM PLM SAMPLE

pl1c



# 20868 Parkside

20868 Parkside Blvd, Ferndale, MI 48220, USA, Ferndale, Michigan, United States 48220

John Wilhelmi

jwilhelmi.enviro@gmail.com

8103369197

3

Width: 11' 2 3/4"  
Length: 14' 3 1/4"  
Area: 160.26 sq ft  
Perimeter: 51'

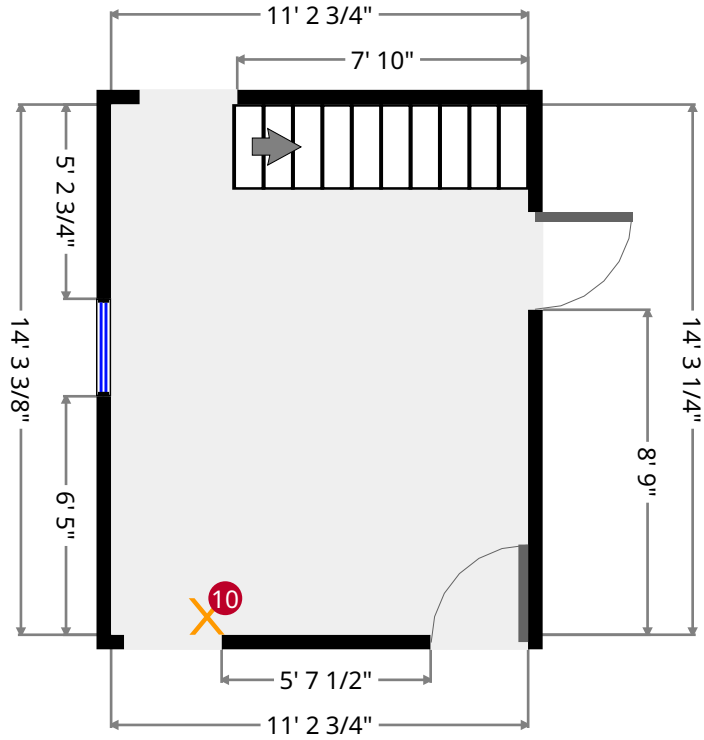
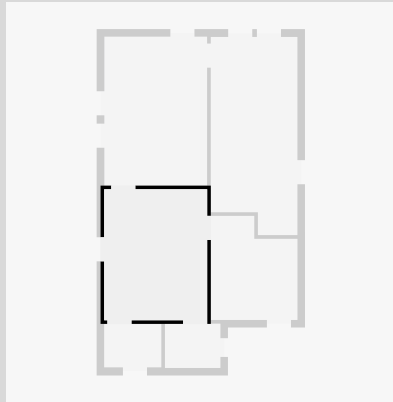

THIS FLOORPLAN IS PROVIDED WITHOUT WARRANTY OF ANY KIND. CENTRAL INDUSTRIAL ASBESTOS LLC DISCLAIMS ANY WARRANTY INCLUDING, WITHOUT LIMITATION, SATISFACTORY QUALITY OR ACCURACY OF DIMENSIONS. INACCURACIES ARE TO BE REPORTED TO CIA PRIOR TO ACTION. CIA MAKES NO WARRANTY IF USE...



# 20868 Parkside

20868 Parkside Blvd, Ferndale, MI 48220, USA, Ferndale, Michigan, United States 48220

**John Wilhelmi**  
jwilhelmi.enviro@gmail.com  
8103369197

10



SUSPECT MATERIAL PLM SAMPLE

ft1a b





# 20868 Parkside

20868 Parkside Blvd, Ferndale, MI 48220, USA, Ferndale, Michigan, United States 48220

John Wilhelmi

jwilhelmi.enviro@gmail.com

8103369197

5

Width: 9' 5 1/4"  
Length: 11' 4 1/8"  
Area: 95.27 sq ft  
Perimeter: 41' 6 3/4"

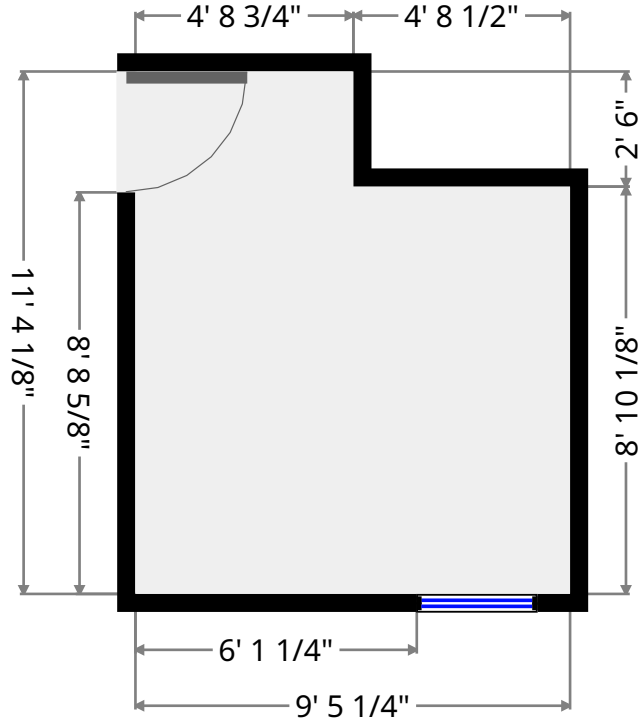
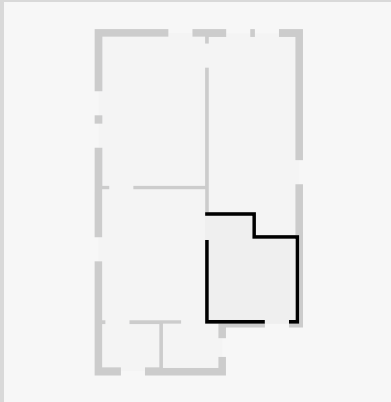

THIS FLOORPLAN IS PROVIDED WITHOUT WARRANTY OF ANY KIND. CENTRAL INDUSTRIAL ASBESTOS LLC DISCLAIMS ANY WARRANTY INCLUDING, WITHOUT LIMITATION, SATISFACTORY QUALITY OR ACCURACY OF DIMENSIONS. INACCURACIES ARE TO BE REPORTED TO CIA PRIOR TO ACTION. CIA MAKES NO WARRANTY IF USE...

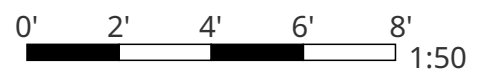

# 20868 Parkside

20868 Parkside Blvd, Ferndale, MI 48220, USA, Ferndale, Michigan, United States 48220

John Wilhelmi

jwilhelmi.enviro@gmail.com

8103369197

4

Width: 4' 10 1/8"  
Length: 6' 1/2"  
Area: 29.21 sq ft  
Perimeter: 21' 9"

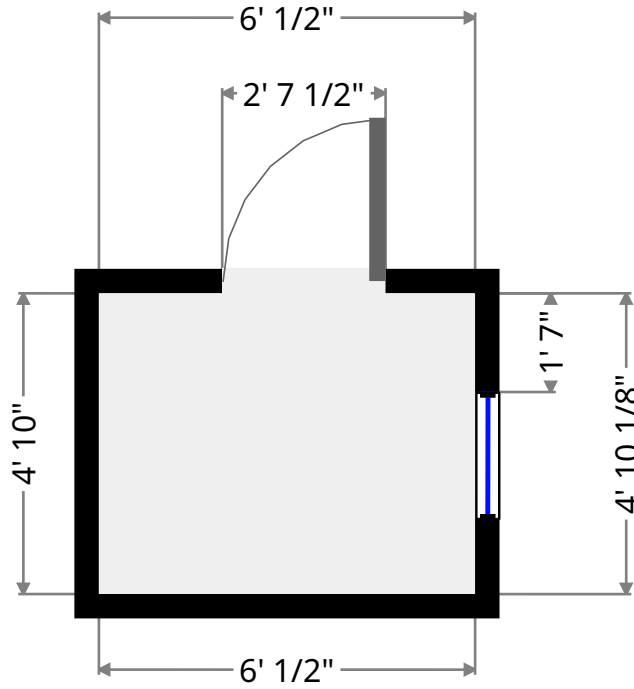
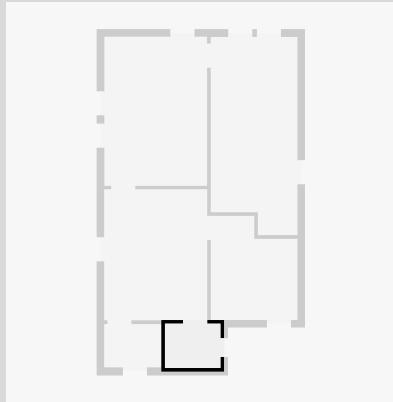

THIS FLOORPLAN IS PROVIDED WITHOUT WARRANTY OF ANY KIND. CENTRAL INDUSTRIAL ASBESTOS LLC DISCLAIMS ANY WARRANTY INCLUDING, WITHOUT LIMITATION, SATISFACTORY QUALITY OR ACCURACY OF DIMENSIONS. INACCURACIES ARE TO BE REPORTED TO CIA PRIOR TO ACTION. CIA MAKES NO WARRANTY IF USE...



# 20868 Parkside

20868 Parkside Blvd, Ferndale, MI 48220, USA, Ferndale, Michigan, United States 48220

John Wilhelmi

jwilhelmi.enviro@gmail.com

8103369197

8

Width: 4' 8 3/8"  
Length: 6' 2 3/4"  
Area: 29.35 sq ft  
Perimeter: 21' 10 5/8"

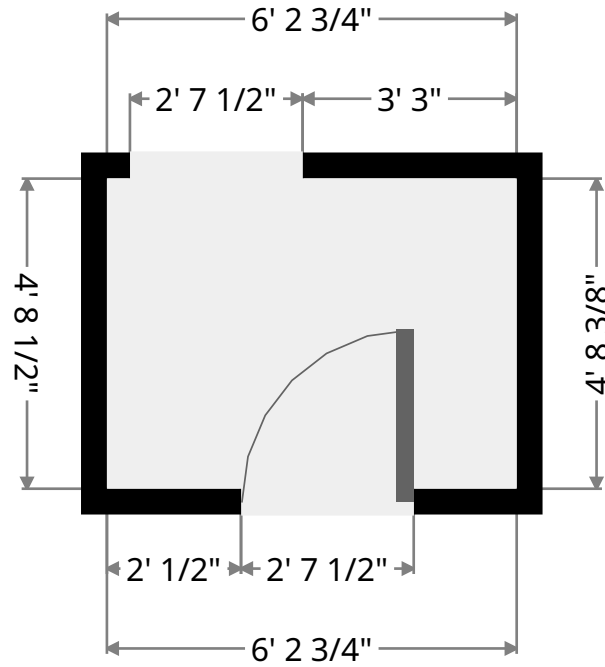
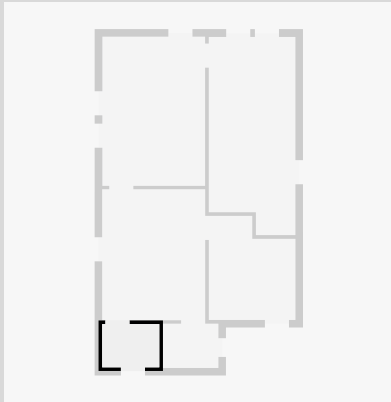

THIS FLOORPLAN IS PROVIDED WITHOUT WARRANTY OF ANY KIND. CENTRAL INDUSTRIAL ASBESTOS LLC DISCLAIMS ANY WARRANTY INCLUDING, WITHOUT LIMITATION, SATISFACTORY QUALITY OR ACCURACY OF DIMENSIONS. INACCURACIES ARE TO BE REPORTED TO CIA PRIOR TO ACTION. CIA MAKES NO WARRANTY IF USE...

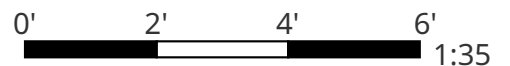

# 20868 Parkside

20868 Parkside Blvd, Ferndale, MI 48220, USA, Ferndale, Michigan, United States 48220

John Wilhelmi

jwilhelmi.enviro@gmail.com

8103369197



## Statistics

Area: 1807 sq ft

3 Floors

3 Bedrooms

2 Bathrooms



## 2nd Floor

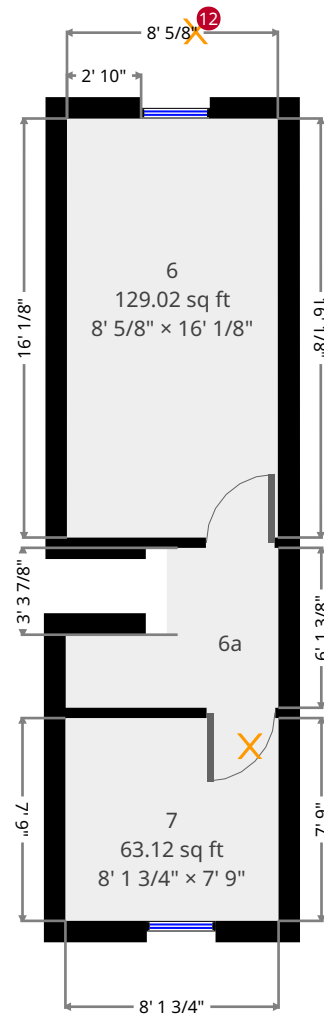

THIS FLOORPLAN IS PROVIDED WITHOUT WARRANTY OF ANY KIND. CENTRAL INDUSTRIAL ASBESTOS LLC DISCLAIMS ANY WARRANTY INCLUDING, WITHOUT LIMITATION, SATISFACTORY QUALITY OR ACCURACY OF DIMENSIONS. INACCURACIES ARE TO BE REPORTED TO CIA PRIOR TO ACTION. CIA MAKES NO WARRANTY IF USE...

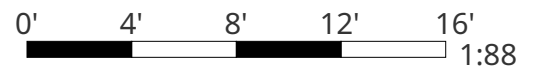

# 20868 Parkside

20868 Parkside Blvd, Ferndale, MI 48220, USA, Ferndale, Michigan, United States 48220

**John Wilhelmi**  
jwilhelmi.enviro@gmail.com  
8103369197

---

12



SUSPECT MATERIAM PLM SAMPLE

r1a b  
r1a b

---

# 20868 Parkside

20868 Parkside Blvd, Ferndale, MI 48220, USA, Ferndale, Michigan, United States 48220

John Wilhelmi

jwilhelmi.enviro@gmail.com

8103369197

7

Width: 7' 9"  
Length: 8' 1 3/4"  
Area: 63.12 sq ft  
Perimeter: 31' 9 1/2"

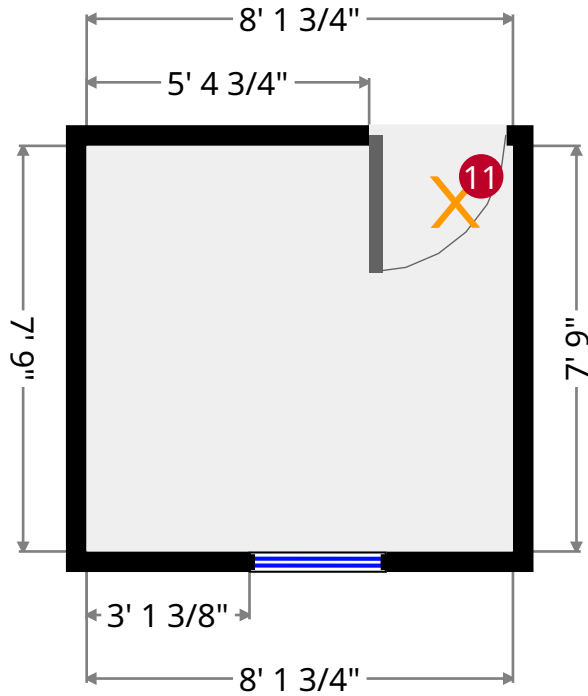
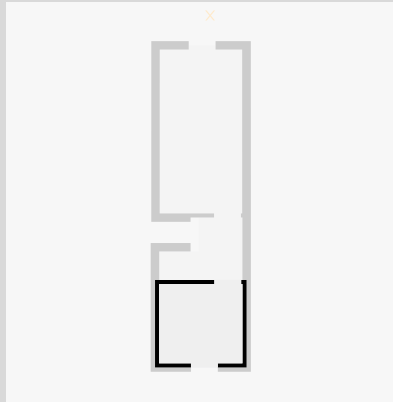

THIS FLOORPLAN IS PROVIDED WITHOUT WARRANTY OF ANY KIND. CENTRAL INDUSTRIAL ASBESTOS LLC DISCLAIMS ANY WARRANTY INCLUDING, WITHOUT LIMITATION, SATISFACTORY QUALITY OR ACCURACY OF DIMENSIONS. INACCURACIES ARE TO BE REPORTED TO CIA PRIOR TO ACTION. CIA MAKES NO WARRANTY IF USE...



# 20868 Parkside

20868 Parkside Blvd, Ferndale, MI 48220, USA, Ferndale, Michigan, United States 48220

**John Wilhelmi**

jwilhelmi.enviro@gmail.com

8103369197

11



SUSPECT MATERIAL PLM SAMPLE

ft1a b



# 20868 Parkside

20868 Parkside Blvd, Ferndale, MI 48220, USA, Ferndale, Michigan, United States 48220

John Wilhelmi  
jwilhelmi.enviro@gmail.com  
8103369197

6

Width: 8' 5/8"  
Length: 16' 1/8"  
Area: 129.02 sq ft  
Perimeter: 48' 1 5/8"

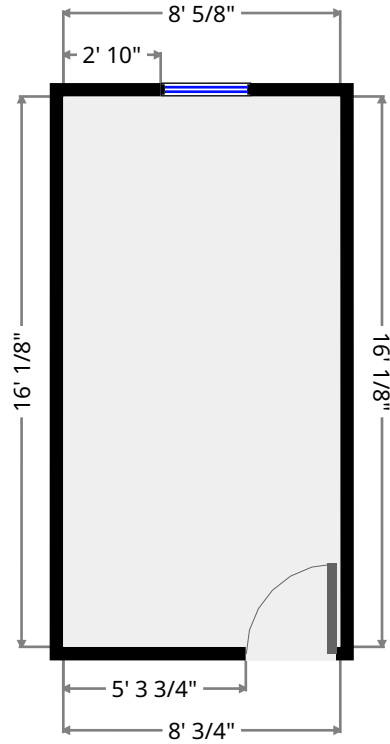
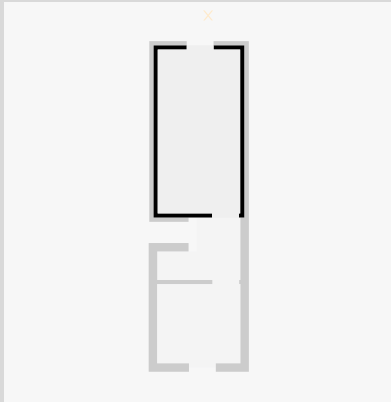

THIS FLOORPLAN IS PROVIDED WITHOUT WARRANTY OF ANY KIND. CENTRAL INDUSTRIAL ASBESTOS LLC DISCLAIMS ANY WARRANTY INCLUDING, WITHOUT LIMITATION, SATISFACTORY QUALITY OR ACCURACY OF DIMENSIONS. INACCURACIES ARE TO BE REPORTED TO CIA PRIOR TO ACTION. CIA MAKES NO WARRANTY IF USE...

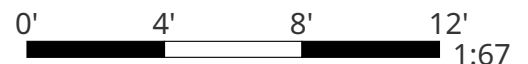



# 20868 Parkside

20868 Parkside Blvd, Ferndale, MI 48220, USA, Ferndale, Michigan, United States 48220

John Wilhelmi

jwilhelmi.enviro@gmail.com

8103369197

## 6a

Width: 6' 1 3/8"  
Length: 8' 1 1/2"  
Area: 35.46 sq ft  
Perimeter: 28' 5 5/8"

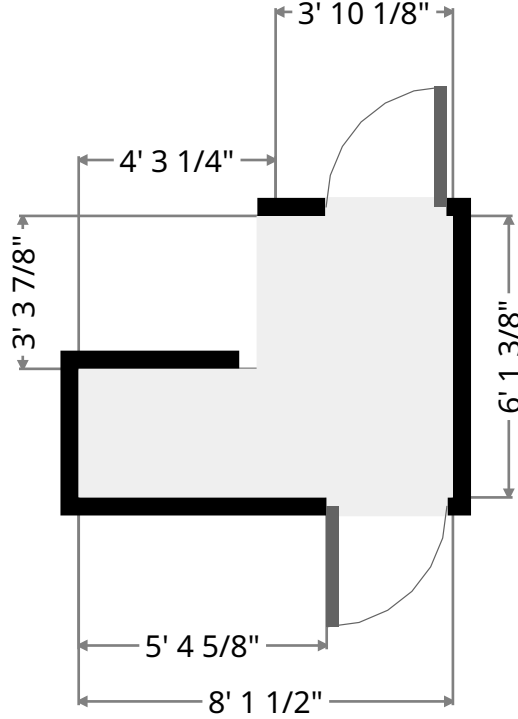
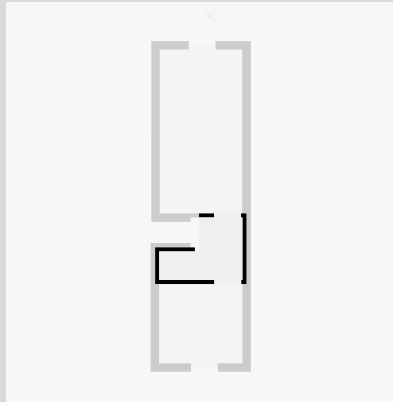

THIS FLOORPLAN IS PROVIDED WITHOUT WARRANTY OF ANY KIND. CENTRAL INDUSTRIAL ASBESTOS LLC DISCLAIMS ANY WARRANTY INCLUDING, WITHOUT LIMITATION, SATISFACTORY QUALITY OR ACCURACY OF DIMENSIONS. INACCURACIES ARE TO BE REPORTED TO CIA PRIOR TO ACTION. CIA MAKES NO WARRANTY IF USE...

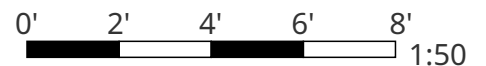

# Certificate of Laboratory Analysis

## Test Method, Polarized Light Microscopy (PLM)



Project : 20868 Parkside Blvd.  
Project # :18-023-149

**Report To:**

Mr. John Wilhelmi  
Central Industrial Asbestos  
10156 Aberdeen Dr.  
Grand Blanc, MI 48439

ARI Report # 18-79897  
Date Collected: 09/25/18  
Date Received: 09/26/18  
Date Analyzed: 10/01/18  
Date Reported: 10/03/18

Sample Information	Asbestos Type/Percent	Non-Asbestos Material
Lab ID #: 79897 - 01 Cust. #: FT 1A Material: Floor Tile Location: FS 3 Appearance: brown,nonfibrous,homogenous Layer: 1 of 6	Asbestos Present: <b>NO</b> No Asbestos Observed	Other - 100%
Lab ID #: 79897 - 01a Cust. #: FT 1A Material: Mastic Location: FS 3 Appearance: clear,nonfibrous,homogenous Layer: 2 of 6	Asbestos Present: <b>NO</b> No Asbestos Observed	Other - 100%
Lab ID #: 79897 - 01b Cust. #: FT 1A Material: Floor Tile Location: FS 3 Appearance: beige,nonfibrous,homogenous Layer: 3 of 6	Asbestos Present: <b>NO</b> No Asbestos Observed	Other - 100%

For Layered Samples, each component will be analyzed and reported separately.

Robert T. Letarte Jr., Laboratory Director

Test Method EPA 600/R-93/116 was used to analyze the above samples. Matrix interference and/or resolution limits may yield false/negative results in certain circumstances. Suspect floor tiles containing <1% should be tested with SEM or TEM. This certificate of analysis relates only to the samples tested and to insure the integrity of the results, may only be reproduced in full. This certificate must not be used by the customer to claim product certification, approval, or endorsement by NVLAP, NIST, or any agency of the Federal Government. APEX Research Inc. is not responsible for the accuracy of the results for layered samples or samples comprising multiple materials. Liability limited to cost of analysis.



# Certificate of Laboratory Analysis

## Test Method, Polarized Light Microscopy (PLM)



Project : 20868 Parkside Blvd.  
Project # :18-023-149

**Report To:**

Mr. John Wilhelmi  
Central Industrial Asbestos  
10156 Aberdeen Dr.  
Grand Blanc, MI 48439

ARI Report # 18-79897  
Date Collected: 09/25/18  
Date Received: 09/26/18  
Date Analyzed: 10/01/18  
Date Reported: 10/03/18

Sample Information	Asbestos Type/Percent	Non-Asbestos Material
Lab ID #: 79897 - 01c Cust. #: FT 1A Material: Mastic Location: FS 3 Appearance: clear,nonfibrous,homogenous Layer: 4 of 6	Asbestos Present: <b>NO</b> No Asbestos Observed	Other - 100%
Lab ID #: 79897 - 01d Cust. #: FT 1A Material: Floor Tile Location: FS 3 Appearance: grey,nonfibrous,homogenous Layer: 5 of 6	Asbestos Present: <b>NO</b> No Asbestos Observed	Other - 100%
Lab ID #: 79897 - 01e Cust. #: FT 1A Material: Mastic Location: FS 3 Appearance: clear,nonfibrous,homogenous Layer: 6 of 6	Asbestos Present: <b>NO</b> No Asbestos Observed	Other - 100%

For Layered Samples, each component will be analyzed and reported separately.

Robert T. Letarte Jr., Laboratory Director

Test Method EPA 600/R-93/116 was used to analyze the above samples. Matrix interference and/or resolution limits may yield false/negative results in certain circumstances. Suspect floor tiles containing <1% should be tested with SEM or TEM. This certificate of analysis relates only to the samples tested and to insure the integrity of the results, may only be reproduced in full. This certificate must not be used by the customer to claim product certification, approval, or endorsement by NVLAP, NIST, or any agency of the Federal Government. APEX Research Inc. is not responsible for the accuracy of the results for layered samples or samples comprising multiple materials. Liability limited to cost of analysis.



# Certificate of Laboratory Analysis

## Test Method, Polarized Light Microscopy (PLM)



Project : 20868 Parkside Blvd.  
Project # :18-023-149

**Report To:**

Mr. John Wilhelmi  
Central Industrial Asbestos  
10156 Aberdeen Dr.  
Grand Blanc, MI 48439

ARI Report # 18-79897  
Date Collected: 09/25/18  
Date Received: 09/26/18  
Date Analyzed: 10/01/18  
Date Reported: 10/03/18

Sample Information	Asbestos Type/Percent	Non-Asbestos Material
Lab ID #: 79897 - 02 Cust. #: FT 1B Material: Floor Tile Location: FS 3 Appearance: brown,nonfibrous,homogenous Layer: 1 of 4	Asbestos Present: <b>NO</b> No Asbestos Observed	Other - 100%
Lab ID #: 79897 - 02a Cust. #: FT 1B Material: Mastic Location: FS 3 Appearance: clear,nonfibrous,homogenous Layer: 2 of 4	Asbestos Present: <b>NO</b> No Asbestos Observed	Other - 100%
Lab ID #: 79897 - 02b Cust. #: FT 1B Material: Floor Tile Location: FS 3 Appearance: beige,nonfibrous,homogenous Layer: 3 of 4	Asbestos Present: <b>NO</b> No Asbestos Observed	Other - 100%

For Layered Samples, each component will be analyzed and reported separately.

Robert T. Letarte Jr., Laboratory Director

Test Method EPA 600/R-93/116 was used to analyze the above samples. Matrix interference and/or resolution limits may yield false/negative results in certain circumstances. Suspect floor tiles containing <1% should be tested with SEM or TEM. This certificate of analysis relates only to the samples tested and to insure the integrity of the results, may only be reproduced in full. This certificate must not be used by the customer to claim product certification, approval, or endorsement by NVLAP, NIST, or any agency of the Federal Government. APEX Research Inc. is not responsible for the accuracy of the results for layered samples or samples comprising multiple materials. Liability limited to cost of analysis.



# Certificate of Laboratory Analysis

## Test Method, Polarized Light Microscopy (PLM)



Project : 20868 Parkside Blvd.  
Project # :18-023-149

**Report To:**

Mr. John Wilhelmi  
Central Industrial Asbestos  
10156 Aberdeen Dr.  
Grand Blanc, MI 48439

ARI Report # 18-79897  
Date Collected: 09/25/18  
Date Received: 09/26/18  
Date Analyzed: 10/01/18  
Date Reported: 10/03/18

Sample Information	Asbestos Type/Percent	Non-Asbestos Material
Lab ID #: 79897 - 02c Cust. #: FT 1B Material: Mastic Location: FS 3 Appearance: clear,nonfibrous,homogenous Layer: 4 of 4	Asbestos Present: <b>NO</b> No Asbestos Observed	Other - 100%
Lab ID #: 79897 - 03 Cust. #: FT 2A Material: Floor Tile Location: FS 7 Appearance: white,nonfibrous,homogenous Layer: 1 of 2	Asbestos Present: <b>NO</b> No Asbestos Observed	Other - 100%
Lab ID #: 79897 - 03a Cust. #: FT 2A Material: Mastic Location: FS 7 Appearance: yellow,nonfibrous,homogenous Layer: 2 of 2	Asbestos Present: <b>NO</b> No Asbestos Observed	Other - 100%

For Layered Samples, each component will be analyzed and reported separately.

Robert T. Letarte Jr., Laboratory Director

Test Method EPA 600/R-93/116 was used to analyze the above samples. Matrix interference and/or resolution limits may yield false/negative results in certain circumstances. Suspect floor tiles containing <1% should be tested with SEM or TEM. This certificate of analysis relates only to the samples tested and to insure the integrity of the results, may only be reproduced in full. This certificate must not be used by the customer to claim product certification, approval, or endorsement by NVLAP, NIST, or any agency of the Federal Government. APEX Research Inc. is not responsible for the accuracy of the results for layered samples or samples comprising multiple materials. Liability limited to cost of analysis.



# Certificate of Laboratory Analysis

## Test Method, Polarized Light Microscopy (PLM)



Project : 20868 Parkside Blvd.  
Project # :18-023-149

**Report To:**

Mr. John Wilhelmi  
Central Industrial Asbestos  
10156 Aberdeen Dr.  
Grand Blanc, MI 48439

ARI Report # 18-79897  
Date Collected: 09/25/18  
Date Received: 09/26/18  
Date Analyzed: 10/01/18  
Date Reported: 10/03/18

Sample Information	Asbestos Type/Percent	Non-Asbestos Material
Lab ID #: 79897 - 04 Cust. #: FT 2B Material: Floor Tile Location: FS 7 Appearance: white,nonfibrous,homogenous Layer: 1 of 2	Asbestos Present: <b>NO</b> No Asbestos Observed	Other - 100%
Lab ID #: 79897 - 04a Cust. #: FT 2B Material: Mastic Location: FS 7 Appearance: yellow,nonfibrous,homogenous Layer: 2 of 2	Asbestos Present: <b>NO</b> No Asbestos Observed	Other - 100%
Lab ID #: 79897 - 05 Cust. #: DW 1A Material: Drywall Location: FS 1 Appearance: beige,fibrous,nonhomogenous Layer: 1 of 2	Asbestos Present: <b>NO</b> No Asbestos Observed	Cellulose - 20% Other - 80%

For Layered Samples, each component will be analyzed and reported separately.

Robert T. Letarte Jr., Laboratory Director

Test Method EPA 600/R-93/116 was used to analyze the above samples. Matrix interference and/or resolution limits may yield false/negative results in certain circumstances. Suspect floor tiles containing <1% should be tested with SEM or TEM. This certificate of analysis relates only to the samples tested and to insure the integrity of the results, may only be reproduced in full. This certificate must not be used by the customer to claim product certification, approval, or endorsement by NVLAP, NIST, or any agency of the Federal Government. APEX Research Inc. is not responsible for the accuracy of the results for layered samples or samples comprising multiple materials. Liability limited to cost of analysis.



# Certificate of Laboratory Analysis

## Test Method, Polarized Light Microscopy (PLM)



Project : 20868 Parkside Blvd.  
Project # :18-023-149

**Report To:**

Mr. John Wilhelmi  
Central Industrial Asbestos  
10156 Aberdeen Dr.  
Grand Blanc, MI 48439

ARI Report # 18-79897  
Date Collected: 09/25/18  
Date Received: 09/26/18  
Date Analyzed: 10/01/18  
Date Reported: 10/03/18

Sample Information	Asbestos Type/Percent	Non-Asbestos Material
Lab ID #: 79897 - 05a Cust. #: DW 1A Material: Joint Compound Location: FS 1 Appearance: white,nonfibrous,homogenous Layer: 2 of 2	Asbestos Present: <b>NO</b> No Asbestos Observed	Other - 100%
Lab ID #: 79897 - 06 Cust. #: DW 1B Material: Drywall Location: FS 2 Appearance: beige,fibrous,nonhomogenous Layer: 1 of 2	Asbestos Present: <b>NO</b> No Asbestos Observed	Cellulose - 20% Other - 80%
Lab ID #: 79897 - 06a Cust. #: DW 1B Material: Joint Compound Location: FS 2 Appearance: white,nonfibrous,homogenous Layer: 2 of 2	Asbestos Present: <b>NO</b> No Asbestos Observed	Other - 100%

For Layered Samples, each component will be analyzed and reported separately.

Robert T. Letarte Jr., Laboratory Director

Test Method EPA 600/R-93/116 was used to analyze the above samples. Matrix interference and/or resolution limits may yield false/negative results in certain circumstances. Suspect floor tiles containing <1% should be tested with SEM or TEM. This certificate of analysis relates only to the samples tested and to insure the integrity of the results, may only be reproduced in full. This certificate must not be used by the customer to claim product certification, approval, or endorsement by NVLAP, NIST, or any agency of the Federal Government. APEX Research Inc. is not responsible for the accuracy of the results for layered samples or samples comprising multiple materials. Liability limited to cost of analysis.



# Certificate of Laboratory Analysis

## Test Method, Polarized Light Microscopy (PLM)



Project : 20868 Parkside Blvd.  
Project # :18-023-149

**Report To:**

Mr. John Wilhelmi  
Central Industrial Asbestos  
10156 Aberdeen Dr.  
Grand Blanc, MI 48439

ARI Report # 18-79897  
Date Collected: 09/25/18  
Date Received: 09/26/18  
Date Analyzed: 10/01/18  
Date Reported: 10/03/18

Sample Information	Asbestos Type/Percent	Non-Asbestos Material
Lab ID #: 79897 - 07 Cust. #: M 1A Material: Mortar Location: Exterior Appearance: grey,nonfibrous,homogenous Layer: 1 of 1	Asbestos Present: <b>NO</b> No Asbestos Observed	Other - 100%
Lab ID #: 79897 - 08 Cust. #: M 1B Material: Mortar Location: Exterior Appearance: grey,nonfibrous,homogenous Layer: 1 of 1	Asbestos Present: <b>NO</b> No Asbestos Observed	Other - 100%
Lab ID #: 79897 - 09 Cust. #: WG 1A Material: Window Glaze Location: FS 9 Appearance: beige,nonfibrous,homogenous Layer: 1 of 1	Asbestos Present: <b>NO</b> No Asbestos Observed	Other - 100%

For Layered Samples, each component will be analyzed and reported separately.

Robert T. Letarte Jr., Laboratory Director

Test Method EPA 600/R-93/116 was used to analyze the above samples. Matrix interference and/or resolution limits may yield false/negative results in certain circumstances. Suspect floor tiles containing <1% should be tested with SEM or TEM. This certificate of analysis relates only to the samples tested and to insure the integrity of the results, may only be reproduced in full. This certificate must not be used by the customer to claim product certification, approval, or endorsement by NVLAP, NIST, or any agency of the Federal Government. APEX Research Inc. is not responsible for the accuracy of the results for layered samples or samples comprising multiple materials. Liability limited to cost of analysis.





# Certificate of Laboratory Analysis

## Test Method, Polarized Light Microscopy (PLM)



Project : 20868 Parkside Blvd.  
Project # :18-023-149

**Report To:**

Mr. John Wilhelmi  
Central Industrial Asbestos  
10156 Aberdeen Dr.  
Grand Blanc, MI 48439

ARI Report # 18-79897  
Date Collected: 09/25/18  
Date Received: 09/26/18  
Date Analyzed: 10/01/18  
Date Reported: 10/03/18

Sample Information	Asbestos Type/Percent	Non-Asbestos Material
Lab ID #: 79897 - 10 Cust. #: WG 1B Material: Window Glaze Location: Exterior Appearance: beige,nonfibrous,homogenous Layer: 1 of 1	Asbestos Present: <b>NO</b> No Asbestos Observed	Other - 100%
Lab ID #: 79897 - 11 Cust. #: R 1A Material: Roofing Location: Exterior Appearance: black,fibrous,homogenous Layer: 1 of 1	Asbestos Present: <b>NO</b> No Asbestos Observed	Fiberglass - 15% Other - 85%
Lab ID #: 79897 - 12 Cust. #: R 1B Material: Roofing Location: Exterior Appearance: black,fibrous,homogenous Layer: 1 of 1	Asbestos Present: <b>NO</b> No Asbestos Observed	Fiberglass - 15% Other - 85%

For Layered Samples, each component will be analyzed and reported separately.

Robert T. Letarte Jr., Laboratory Director

Test Method EPA 600/R-93/116 was used to analyze the above samples. Matrix interference and/or resolution limits may yield false/negative results in certain circumstances. Suspect floor tiles containing <1% should be tested with SEM or TEM. This certificate of analysis relates only to the samples tested and to insure the integrity of the results, may only be reproduced in full. This certificate must not be used by the customer to claim product certification, approval, or endorsement by NVLAP, NIST, or any agency of the Federal Government. APEX Research Inc. is not responsible for the accuracy of the results for layered samples or samples comprising multiple materials. Liability limited to cost of analysis.



# Certificate of Laboratory Analysis

## Test Method, Polarized Light Microscopy (PLM)



Project : 20868 Parkside Blvd.  
Project # :18-023-149

**Report To:**

Mr. John Wilhelmi  
Central Industrial Asbestos  
10156 Aberdeen Dr.  
Grand Blanc, MI 48439

ARI Report # 18-79897  
Date Collected: 09/25/18  
Date Received: 09/26/18  
Date Analyzed: 10/01/18  
Date Reported: 10/03/18

Sample Information	Asbestos Type/Percent	Non-Asbestos Material
Lab ID #: 79897 - 13 Cust. #: S 1A Material: Siding Shingles Location: Exterior Appearance: black, fibrous, nonhomogenous Layer: 1 of 1	Asbestos Present: <b>NO</b> No Asbestos Observed	Cellulose - 60% Other - 40%
Lab ID #: 79897 - 14 Cust. #: S 1B Material: Siding Shingles Location: Exterior Appearance: black, fibrous, nonhomogenous Layer: 1 of 1	Asbestos Present: <b>NO</b> No Asbestos Observed	Cellulose - 60% Other - 40%
Lab ID #: 79897 - 15 Cust. #: T 1A Material: Transite Location: Exterior Appearance: grey, fibrous, homogenous Layer: 1 of 1	Asbestos Present: <b>YES</b> Chrysotile - 15%	Other - 85%

For Layered Samples, each component will be analyzed and reported separately.

Robert T. Letarte Jr., Laboratory Director

Test Method EPA 600/R-93/116 was used to analyze the above samples. Matrix interference and/or resolution limits may yield false/negative results in certain circumstances. Suspect floor tiles containing <1% should be tested with SEM or TEM. This certificate of analysis relates only to the samples tested and to insure the integrity of the results, may only be reproduced in full. This certificate must not be used by the customer to claim product certification, approval, or endorsement by NVLAP, NIST, or any agency of the Federal Government. APEX Research Inc. is not responsible for the accuracy of the results for layered samples or samples comprising multiple materials. Liability limited to cost of analysis.



# Certificate of Laboratory Analysis

## Test Method, Polarized Light Microscopy (PLM)



Project : 20868 Parkside Blvd.  
Project # :18-023-149

**Report To:**

Mr. John Wilhelmi  
Central Industrial Asbestos  
10156 Aberdeen Dr.  
Grand Blanc, MI 48439

ARI Report # 18-79897  
Date Collected: 09/25/18  
Date Received: 09/26/18  
Date Analyzed: 10/01/18  
Date Reported: 10/03/18

Sample Information	Asbestos Type/Percent	Non-Asbestos Material
Lab ID #: 79897 - 16 Cust. #: T 1B Material: Transite Location: Exterior Appearance: Layer: of	Asbestos Present:  NOT ANALYZED	
Lab ID #: 79897 - 17 Cust. #: DI 1A Material: Duct Insulation Location: FS 9 Appearance: beige, fibrous, homogenous Layer: 1 of 1	Asbestos Present: <b>YES</b> Chrysotile - 50%	Cellulose - 25% Other - 25%
Lab ID #: 79897 - 18 Cust. #: DI 1B Material: Duct Insulation Location: FS 9 Appearance: Layer: of	Asbestos Present:  No Asbestos Observed	

For Layered Samples, each component will be analyzed and reported separately.

Robert T. Letarte Jr., Laboratory Director

Test Method EPA 600/R-93/116 was used to analyze the above samples. Matrix interference and/or resolution limits may yield false/negative results in certain circumstances. Suspect floor tiles containing <1% should be tested with SEM or TEM. This certificate of analysis relates only to the samples tested and to insure the integrity of the results, may only be reproduced in full. This certificate must not be used by the customer to claim product certification, approval, or endorsement by NVLAP, NIST, or any agency of the US Government. APEX Research Inc. is not responsible for the accuracy of the results for layered samples or samples comprising multiple materials. Liability limited to cost of analysis.



# Certificate of Laboratory Analysis

## Test Method, Polarized Light Microscopy (PLM)



Project : 20868 Parkside Blvd.  
Project # :18-023-149

**Report To:**

Mr. John Wilhelmi  
Central Industrial Asbestos  
10156 Aberdeen Dr.  
Grand Blanc, MI 48439

ARI Report # 18-79897  
Date Collected: 09/25/18  
Date Received: 09/26/18  
Date Analyzed: 10/01/18  
Date Reported: 10/03/18

Sample Information	Asbestos Type/Percent	Non-Asbestos Material
Lab ID #: 79897 - 19 Cust. #: DI 1C Material: Duct Insulation Location: FS 9 Appearance: Layer: of	Asbestos Present:  No Asbestos Observed	
Lab ID #: 79897 - 20 Cust. #: PL 1A Material: Texture Location: FS 2 Appearance: white,nonfibrous,homogenous Layer: 1 of 2	Asbestos Present: <b>NO</b> No Asbestos Observed	Other - 100%
Lab ID #: 79897 - 20a Cust. #: PL 1A Material: Plaster Base Coat Location: FS 2 Appearance: grey,fibrous,homogenous Layer: 2 of 2	Asbestos Present: <b>NO</b> No Asbestos Observed	Cellulose - 5% Other - 95%

For Layered Samples, each component will be analyzed and reported separately.

Robert T. Letarte Jr., Laboratory Director

Test Method EPA 600/R-93/116 was used to analyze the above samples. Matrix interference and/or resolution limits may yield false/negative results in certain circumstances. Suspect floor tiles containing <1% should be tested with SEM or TEM. This certificate of analysis relates only to the samples tested and to insure the integrity of the results, may only be reproduced in full. This certificate must not be used by the customer to claim product certification, approval, or endorsement by NVLAP, NIST, or any agency of the US Government. APEX Research Inc. is not responsible for the accuracy of the results for layered samples or samples comprising multiple materials. Liability limited to cost of analysis.



# Certificate of Laboratory Analysis

## Test Method, Polarized Light Microscopy (PLM)



Project : 20868 Parkside Blvd.  
Project # :18-023-149

**Report To:**

Mr. John Wilhelmi  
Central Industrial Asbestos  
10156 Aberdeen Dr.  
Grand Blanc, MI 48439

ARI Report # 18-79897  
Date Collected: 09/25/18  
Date Received: 09/26/18  
Date Analyzed: 10/01/18  
Date Reported: 10/03/18

Sample Information	Asbestos Type/Percent	Non-Asbestos Material
Lab ID #: 79897 - 21 Cust. #: PL 1B Material: Texture Location: FS 1 Appearance: white,nonfibrous,homogenous Layer: 1 of 3	Asbestos Present: <b>NO</b> No Asbestos Observed	Other - 100%
Lab ID #: 79897 - 21a Cust. #: PL 1B Material: Plaster Finish Coat Location: FS 1 Appearance: white,nonfibrous,homogenous Layer: 2 of 3	Asbestos Present: <b>NO</b> No Asbestos Observed	Other - 100%
Lab ID #: 79897 - 21b Cust. #: PL 1B Material: Plaster Base Coat Location: FS 1 Appearance: grey,fibrous,homogenous Layer: 3 of 3	Asbestos Present: <b>NO</b> No Asbestos Observed	Cellulose - 5% Other - 95%

For Layered Samples, each component will be analyzed and reported separately.

Robert T. Letarte Jr., Laboratory Director

Test Method EPA 600/R-93/116 was used to analyze the above samples. Matrix interference and/or resolution limits may yield false/negative results in certain circumstances. Suspect floor tiles containing <1% should be tested with SEM or TEM. This certificate of analysis relates only to the samples tested and to insure the integrity of the results, may only be reproduced in full. This certificate must not be used by the customer to claim product certification, approval, or endorsement by NVLAP, NIST, or any agency of the US Government. APEX Research Inc. is not responsible for the accuracy of the results for layered samples or samples comprising multiple materials. Liability limited to cost of analysis.



# Certificate of Laboratory Analysis

## Test Method, Polarized Light Microscopy (PLM)



Project : 20868 Parkside Blvd.  
Project # :18-023-149

**Report To:**

Mr. John Wilhelmi  
Central Industrial Asbestos  
10156 Aberdeen Dr.  
Grand Blanc, MI 48439

ARI Report # 18-79897  
Date Collected: 09/25/18  
Date Received: 09/26/18  
Date Analyzed: 10/01/18  
Date Reported: 10/03/18

Sample Information	Asbestos Type/Percent	Non-Asbestos Material
Lab ID #: 79897 - 22 Cust. #: PL 1C Material: Texture Location: FS 2 Appearance: white,nonfibrous,homogenous Layer: 1 of 3	Asbestos Present: <b>NO</b> No Asbestos Observed	Other - 100%
Lab ID #: 79897 - 22a Cust. #: PL 1C Material: Plaster Finish Coat Location: FS 2 Appearance: white,nonfibrous,homogenous Layer: 2 of 3	Asbestos Present: <b>NO</b> No Asbestos Observed	Other - 100%
Lab ID #: 79897 - 22b Cust. #: PL 1C Material: Plaster Base Coat Location: FS 2 Appearance: grey,fibrous,homogenous Layer: 3 of 3	Asbestos Present: <b>NO</b> No Asbestos Observed	Cellulose - 5% Other - 95%

For Layered Samples, each component will be analyzed and reported separately.

Robert T. Letarte Jr., Laboratory Director

Test Method EPA 600/R-93/116 was used to analyze the above samples. Matrix interference and/or resolution limits may yield false/negative results in certain circumstances. Suspect floor tiles containing <1% should be tested with SEM or TEM. This certificate of analysis relates only to the samples tested and to insure the integrity of the results, may only be reproduced in full. This certificate must not be used by the customer to claim product certification, approval, or endorsement by NVLAP, NIST, or any agency of the US Government. APEX Research Inc. is not responsible for the accuracy of the results for layered samples or samples comprising multiple materials. Liability limited to cost of analysis.



## APEX Research, Inc.

11054 Hi Tech Drive, Whitmore Lake, MI 48189. Phone: (734) 449-9990, Fax (734) 449-9991 www.ApexMI.com



## CITY OF ROYAL OAK TOWNSHIP CONTRACT

Customer Name: John Wilhelmi

Address:

City, St., Zip:

Phone:

Fax:

Turn Around Times: (Circle One and Indicate type/size)

RUSH

48 hour

Other:

Step all plaster analysis on first

positive layer

24 hour

5 DAY

7-10

(Test TR Points)

Asbestos:

Lead / Cd / Chrome

MOI6:

TEM:

Date of Survey: 9/25/18

Project: 20868 Parkside Blvd.

Project: 18-023-149

Contact Person: John Wilhelmi

Email: JWilhelmi.enviro@gmail.com

\*\*\*Terms and conditions on the other side.

Bulk X

Bulk

Bulk

Bulk/NUB

Wipe

Wipe

Air/Zenon/Airgenco/J

NIOSH /402

Point Count

Air

EPA Level II

EPA Level II

PUM

Paint

MOBIS

EPA Level II

Lab Use Only

Log-In: \_\_\_\_\_

Report: \_\_\_\_\_

Fax: \_\_\_\_\_

Verbal: \_\_\_\_\_

Email: \_\_\_\_\_

Lab ID	Customer ID #	Material	Location	Volume	Homogenous Area	Results
1	FT 1A	Floor Tile/Mastic	FS 3		HA1	
2	FT 1B	Floor Tile/Mastic	FS 3		HA1	
3	FT 2A	Floor Tile/Mastic	FS 7		HA2	
4	FT 2B	Floor Tile/Mastic	FS 7		HA2	
5	DW 1A	Drywall	FS 1		HA3	
6	DW 1B	Drywall	FS 2		HA3	
7	M 1A	Mortar	FS Exterior		HA4	
8	M 1B	Mortar	FS Exterior		HA4	
9	WG 1A	Window Glaze	FS 9		HA5	
10	WG 1B	Window Glaze	FS Exterior		HA5	
11	R 1A	Roofing	FS Exterior		HA6	
12	R 1B	Roofing	FS Exterior		HA6	
13	S 1A	Siding Shingles	FS Exterior		HA7	
14	S 1B	Siding Shingles	FS Exterior		HA7	
15	T 1A	Transite	FS Exterior		HA8	

Relinquished By: J. Wilhelmi

Date: 09/25/18

Revision K1 Date: October 2011

Received By: J. Wilhelmi

Time/Date: 9-26-18

Relinquished By: \_\_\_\_\_

Received By: \_\_\_\_\_

Time/Date: \_\_\_\_\_

RECEIVED  
SEP 26 2018

APEX RESEARCH, INC.

# APEX Research, Inc.

11054 H6 Tech Drive, Whitmore Lake, MI 48189. Phone: (734) 449-9990, Fax (734) 449-9991 www.ApexMI.com



**CITY OF ROYAL OAK TOWNSHIP CONTRACT**

Customer Name: John Wilhelmi  
 Address:  
 City, St., Zip:  
 Phone: \_\_\_\_\_ Fax: \_\_\_\_\_

Date of Survey: 9/25/18  
 Project: 20868 Parkside Blvd.  
 Project: 18-023-149  
 Contact Person: John Wilhelmi  
 Email: JWilhelmi.enviro@gmail.com

Lab Use Only  
 Log-In: \_\_\_\_\_  
 Report: \_\_\_\_\_  
 Fax: \_\_\_\_\_  
 Verbal: \_\_\_\_\_  
 Email: \_\_\_\_\_

Turn Around Times (Circle One and Indicate typewrite)

Rush 24 hour  
 48 hour 5 DAY  
 Other: 111 Y.E.S.  
Step all plaster analysis on first positive layer

\*\*\*Terms and conditions on the other side.

Asbestos: Bulk X  
 Wipe \_\_\_\_\_ Point Count \_\_\_\_\_ P.C.M. \_\_\_\_\_  
 Lead / Cad / Chromium: \_\_\_\_\_  
 Mold: \_\_\_\_\_  
 Bulk: \_\_\_\_\_ Air/Zefon/Alergen/CO2 \_\_\_\_\_  
 Bulk/NUB: \_\_\_\_\_ NIOSH /492 \_\_\_\_\_ EPA Level II \_\_\_\_\_

Soil \_\_\_\_\_  
 Tape \_\_\_\_\_  
 Other \_\_\_\_\_

Lab ID	Customer ID #	Material	Location	Volume	Homogenous Area	Results
16	T 1B	Transite	FS Exterior		HA8	
17	01 1A	Duct Insulation	FS 9		HA9	
18	01 1B	Duct Insulation	FS 9		HA9	
19	01 1C	Duct Insulation	FS 9		HA9	
20	PL 1A	Plaster	FS 2		HA10	
21	PL 1B	Plaster	FS 1		HA10	
22	PL 1C	Plaster	FS 2		HA10	
	0 0	0	FS 0		0	
	0 0	0	FS 0		0	
	0 0	0	FS 0		0	
	0 0	0	FS 0		0	
	0 0	0	FS 0		0	
	0 0	0	FS 0		0	
	0 0	0	FS 0		0	
	0 0	0	FS 0		0	

Relinquished By: J. Wilhelmi

Received By: \_\_\_\_\_

Date: 09/25/18

Time/Date: \_\_\_\_\_

Relinquished By: \_\_\_\_\_

Received By: \_\_\_\_\_

Time/Date: \_\_\_\_\_

Revision R3 Date: October 2010

**RECEIVED**

SEP 26 2018

APEX RESEARCH





## INSTRUCTIONS FOR THE ASBESTOS NOTIFICATION SYSTEM (ANS)

Register your business. You will need to register the business using the business owner information. **Once you register you will receive a confirmation email that you must click on to confirm registration.** After registration is confirmed you can log into the Asbestos Notification System.

Once you are able to log into the site, you will see several tabs - **Workspace, Notification Management, Notification, Profile and Manage Delegated Authority.**

The **Manage Delegated Authority** allows you to add additional users to the system. . You can add multiple delegated users to enter notifications for your business.

The **Profile Tab** allows you to update your business information or change your password

The **Workspace Tab** is where you begin your notification entry. Start your notification by clicking the button that looks like



on the right side of the screen. You can also click on the **Notification Tab** to start a new notification.

Once you are under the **Notification Tab**, you must fill in all of the required information. If there is an exclamation point (!) on any tab, information is missing or incorrect and you **will not** be able to submit your notification.

Notifications that are saved for further editing and are not submitted can be found under the **Workspace Tab**. You can revise your notification by clicking on the  tab.

Once you submit your notification, it will be saved under the **Notification Management Tab**. Under the Actions header, you can view attachments, copy, revise and cancel your notifications. You can sort by clicking the headers, and export information to Excel. You can click on the document number to print or save it.

The delete button  is for housekeeping purposes only. REMEMBER – if you delete a notification you are also deleting all notifications associated with it and will not be able to edit them once they are deleted.

**You must submit your Demolition and Renovation notifications separate and mark the appropriate project type!**

- The ANS currently supports the following browsers:
  - Internet Explorer 10 & 11.  
Note: In IE the ANS is presently experiencing issues when generating the PDF and Excel spreadsheet. You must select the option to Always Allow pop-ups for “\*.state.mi.us” in order for these features to work.
  - Firefox 25 and above
  - Chrome
  - Safari

If you have questions pertaining to the new system, please contact Kim Dohm at 517-284-6777 or [dohmk@michigan.gov](mailto:dohmk@michigan.gov).



# Understanding the Asbestos NESHAP

Fact Sheet

The Clean Air Act (CAA) requires the U.S. Environmental Protection Agency (U.S. EPA) to develop and enforce regulations to protect the general public from exposure to airborne contaminants that are known to be hazardous to human health. The U.S. EPA established the National Emission Standards for Hazardous Air Pollutants (NESHAP) under the authority of Section 112 of the CAA, and asbestos was one of the first hazardous air pollutants regulated. The Asbestos NESHAP was promulgated on April 6, 1973, and it was revised in 1990.

Asbestos was widely used in buildings for fireproofing, thermal and acoustical insulation, condensation control, and decoration. It was sprayed on beams and ceilings, used to cover piping and boilers, and sprayed onto ducts. Asbestos was used extensively until the 1970s when U.S. EPA banned certain applications.

The Asbestos NESHAP protects the public by minimizing the release of asbestos fibers during renovation and demolition activities. Accordingly, this regulation specifies work practices to be followed for demolitions and renovations of all structures, installations, and buildings. Privately owned residential dwellings or apartments that are demolished for urban renewal or as part of a public or commercial project would be covered under the NESHAP regulations. Residential dwellings containing four units or less under private control or ownership would not be subject to the NESHAP. In addition, the Asbestos NESHAP contains notification requirements for the owner of the building and/or the contractor. Both the owner and contractor(s) are liable for compliance with the Asbestos NESHAP requirements.

The purpose of this publication is to describe who is subject to the Asbestos NESHAP and to explain the requirements of this standard. A brief glossary is provided at the end of this document to assist in understanding some of the terms (appearing in **boldface** text) discussed in this fact sheet. This fact sheet is to be used only as a guide and is not a substitute for reading and understanding the final rule which is found in Title 40, Part 61, Subpart M of the Code of Federal Regulations (40 CFR Part 61). For a copy of the final rule, see the "Where To Get Additional Information" section on page 10.

## **WHAT AGENCIES REGULATE ASBESTOS?**

There are three state agencies in Michigan that regulate **asbestos**: the Michigan Department of Environmental Quality (DEQ), the Michigan Department of Licensing and Regulatory Affairs (DLARA) and the Michigan Department of State Police (MSP). The DEQ is concerned about the release of asbestos fibers to the outer air and proper waste disposal, while DLARA focuses on worker protection during renovation and demolition activities, contractor licensing, and worker training.

- **Michigan Department of Environmental Quality (DEQ)**

The U.S. EPA has delegated the Air Quality Division (AQD) of the DEQ with the authority to enforce the Asbestos NESHAP in Michigan. In addition, the state of Michigan has adopted the federal regulations into the Michigan Administrative Code (MAC), 1995 AACS R 336.1942 (Rule 942), which is in effect as of November 30, 2000 and revised September 11, 2008. A violation of the federal asbestos regulations is also a violation of the MAC. The AQD administers the asbestos NESHAP for the entire state: reviewing the notifications, inspecting demolitions and asbestos removals, and initiation enforcement actions when violations occur. Approximately 7000

## Understanding the Asbestos NESHAP

notifications are received each year by this agency and are reviewed for completeness and timeliness. Inspections are made based on contractor history, areas of the state, and type of project. Inspections are also performed in response to complaints. The U.S. EPA can and does conduct independent inspections of NESHAP projects.

The Waste Management Division of the DEQ regulates disposal of asbestos.

- **Michigan Department of Licensing and Regulatory Affairs (DLARA)**

The Occupational Health Division of DLARA implements the Asbestos Abatement Contractors Licensing Act, the Michigan Occupational Safety and Health Act (MIOSHA), the Asbestos Workers Accreditation Act, and the MIOASHA Asbestos Construction Standard. Some of the requirements in these acts and standards include work practices, training, and project notification. DLARA also licenses those who train asbestos removal workers about the regulations. For more information about the DLARA Asbestos Program, see the "Where to Get Additional Information" section on page 10.

- **Michigan Department of State Police (MSP)**

The Hazardous Materials and Investigations Unit of the MSP is responsible for enforcing the U.S. Department of Transportation's (U.S.DOT) regulations regarding shipping and transporting of packaged materials by highway. Asbestos, transported for disposal as a hazardous material, is regulated under 49 CFR Parts 100-185. For more information, refer to the "Where to Get Additional Information" section on page 10.

### **ASBESTOS NESHAP APPLICABILITY**

To determine applicability to the Asbestos NESHAP, three questions must be answered:

- ☞ Is the facility regulated by the NESHAP?
- ☞ Is the activity a demolition or a renovation?
- ☞ Does the amount of **regulated asbestos-containing material (RACM)** meet or exceed the thresholds?

- ☞ **Is the Facility Regulated by the Asbestos NESHAP?**

A **facility** subject to the NESHAP can be any institutional, commercial, or industrial structure, **installation**, or building. Examples include, but are not limited to:

- ✓ Bridges;
- ✓ Tunnels;
- ✓ Docked ships;
- ✓ Military installations, including dependent housing;
- ✓ Chemical/power plant installations;
- ✓ Indoor shopping malls;
- ✓ School buildings in a school district;
- ✓ Post office buildings;
- ✓ Apartment buildings containing five or more dwelling units;
- ✓ Certain condominiums, cooperatives, and lofts;
- ✓ Dwellings which are part of an urban renewal project, highway construction, shopping mall, or other private development (which are not privately owned and held);

## Understanding the Asbestos NESHAP

- ✓ Groups of residential buildings under control of the same owner/operator and part of the same renovation/demolition project (even if the buildings are not proximate to each other);
- ✓ Amusement parks or state fairgrounds;
- ✓ Jails or prisons;
- ✓ Nursing homes or homes for disabled persons;
- ✓ Parking garages;
- ✓ Farms;
- ✓ Churches, monasteries, convents, or rectories; and
- ✓ Residential dwellings intentionally burned for fire training, etc.

Some examples of facilities not subject to the Asbestos NESHAP include:

- ✓ Privately owned homes, not demolished for urban renewal or as part of a public or commercial project;
- ✓ Privately-owned, multi-dwelling units with four or less dwelling units; and
- ✓ Mobile sources.

### **Is the Activity a Demolition or a Renovation?**

A **demolition** is the wrecking or taking out of any load-supporting **structural member** of a facility together with any related handling operations or the intentional burning of any facility. A **renovation** is altering a facility or one or more facility components in any way, including the **stripping or removal** of RACM from a facility component (excluding operations in which load-supporting structural members are wrecked or taken out). Table 1 lists some examples of demolition and renovation activities.

*Table 1. Examples of Demolition and Renovation Activities*

Demolition	Renovation
The wrecking or taking out of any load-supporting structural member or the intentional burning of any facility.	Altering a facility or one or more facility components in any way, including the stripping or removal of RACM from a facility component, but excluding operations in which load-supporting structural members are wrecked or taken out.
<ul style="list-style-type: none"> <li>• Wrecking or taking out building Beams or load-supporting walls;</li> <li>• Removing the structural steel Supports of outdoor pipe racks;</li> <li>• Intentional burning, including intentional burning for fire training (this includes privately-owned, single-family dwellings);</li> <li>• Wrecking or tearing down a portion of a structure that is load-supporting; or</li> <li>• Renovating or remodeling a facility that includes wrecking or removing a load-supporting wall or component, etc.</li> </ul>	<ul style="list-style-type: none"> <li>• Scraping asbestos insulation off a ceiling;</li> <li>• Removing a boiler covered with friable asbestos from a building;</li> <li>• Removing pipe covered with friable asbestos from a pipe rack;</li> <li>• Gross removal of boiler asbestos insulation;</li> <li>• Glove bag stripping of asbestos pipe wrap;</li> <li>• Drilling through asbestos ceiling plaster to build a dropped ceiling;</li> <li>• Removing soundproofing, ceiling tiles, or plaster containing asbestos;</li> <li>• Removing vinyl asbestos floor tile or any asbestos-containing material that is normally nonfriable that is <b>in poor condition</b> (cracking, peeling, or showing other signs of deterioration). For example, it can be crumbled or pulverized by hand pressure; or</li> <li>• Activities that will render nonfriable material friable, such as grinding, sanding, crumbling, pulverizing, sawing, or other abrasive action, etc.</li> </ul>

### *☞ When Must an Asbestos Inspection and Detection Survey Be Completed?*

The Asbestos NESHAP requires that a thorough inspection be conducted for all renovations and all demolitions. All inspections must be completed before the commencement of a subject renovation and/or demolition activity, and the contractor performing the inspection must be listed on the joint DEQ/DLARA "Notification of Intent to Renovate/Demolish" form. Inspections utilizing just visual examination are not acceptable unless the building is primarily steel and concrete materials or no materials in the building are likely to contain asbestos. Both contractors and their legal representatives, as well as owners and their legal representatives, are fully responsible for fulfilling the Asbestos NESHAP inspection requirements.

Although the Asbestos NESHAP does not specifically state that the person who does the inspection and conducts the site survey be trained in recognizing potential asbestos-containing material, the prerequisite of a trained survey inspector still may be a requirement under the Occupational Safety and Health Administration's (OSHA) Asbestos Standards. The federal OSHA Asbestos Standard for Construction (29 CFR 1926.1101) and the OSHA Asbestos Standard for General Industry (29 CFR 1910.1001) are administered by the DLARA's, MIOSHA program. Each standard requires that all **public and commercial buildings** constructed prior to 1981, where employees may enter, work, or contact building materials, must be inspected for **asbestos-containing materials (ACM)**. This includes any houses, garages, apartments, etc. where employees work and may disturb asbestos. Additionally, all such vacant buildings scheduled for renovation or demolition must have an asbestos building survey completed prior to the start of the work.

Inspections under the OSHA standards must also adhere to the AHERA inspection protocol and be performed by a Michigan-accredited asbestos building inspector or a Certified Industrial Hygienist (CIH). The building survey must document the presence, location, and quantity of all "suspect" ACM. Laboratory analysis information should be a part of the building survey document and be kept by the building owner.

Once an asbestos building survey has confirmed or assumed the presence of ACM, all employees who work around, but do not disturb the ACM (i.e., persons conducting janitorial, building maintenance, and/or housekeeping activities) must receive, at a minimum, asbestos awareness training. Additionally, employees who may disturb ACM (i.e., persons working with any of the mechanical systems that have ACM) are required to have additional asbestos-related training. See the section entitled, "Where to Get Additional Information," for further assistance with the standard's inspection, licensing, and training requirements.

### *☞ Does the Amount of RACM Meet or Exceed the Thresholds?*

Thoroughly inspect the facility for asbestos, including **Category I and Category II nonfriable asbestos-containing material (ACM)**. Determine if the combined amount of RACM is at or above the thresholds listed in Table 2. RACM includes:

- ✓ Friable asbestos material;
- ✓ Category I nonfriable ACM that has become friable;
- ✓ Category I nonfriable ACM that will be or has been subjected to sanding, **grinding, cutting,** or abrading; or
- ✓ Category II nonfriable ACM that has a high probability of becoming or has become crumbled, pulverized, or reduced to powder by the forces expected to act on the material during demolition or renovation.

To determine whether **planned renovation operations** involving individual **nonscheduled renovation operations** are subject, predict the combined additive amount of RACM to be removed during a calendar year of January 1 through December 31.

## Understanding the Asbestos NESHAP

Table 2. Applicability Thresholds

Location of Asbestos	Threshold Level of RACM
Pipes	80 linear meters (260 linear feet)
Other facility components	15 square meters (160 square feet)
Asbestos that is already off facility components where the length or area could not be measured previously.	1 cubic meter (35 cubic feet)

Any demolition or renovation activity that meets or exceeds the applicability thresholds in Table 2 is subject to all the renovation/demolition requirements of the NESHAP. Demolition activities below the thresholds (even for facilities with no asbestos) are subject to the notification requirement. Figure 1 summarizes the process for determining applicability to the Asbestos NESHAP.

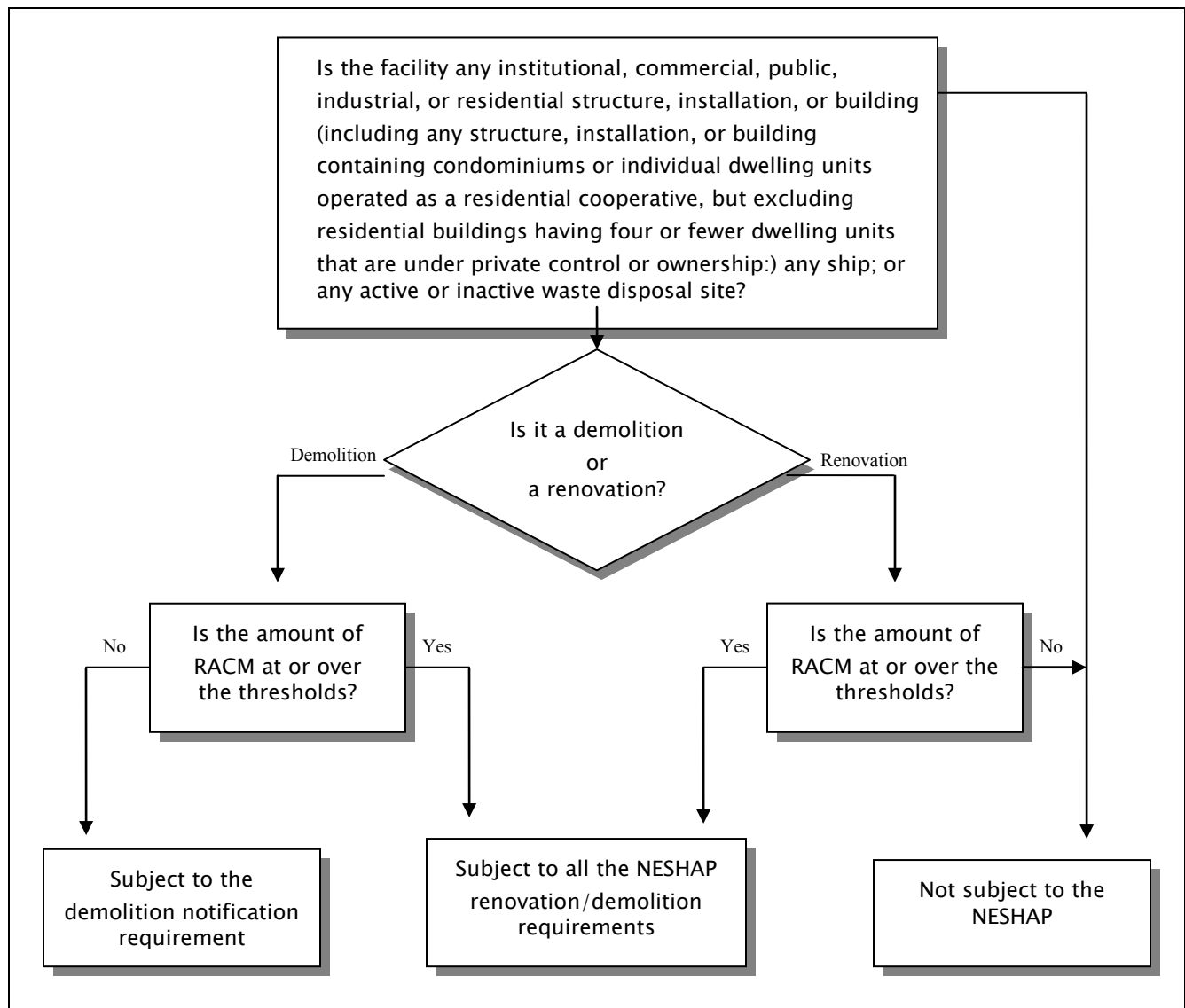

Figure 1. Flowchart for Determining Applicability to the Asbestos NESHAP

## Understanding the Asbestos NESHAP

Examples of operations that are neither demolitions nor subject renovations and, therefore, not subject to the Asbestos NESHAP include:

- ✓ Renovation below the threshold levels unless it is above the threshold levels cumulatively in a calendar year (notification may be required by DLARA);
- ✓ Removal of **nonfriable asbestos-containing material**, as long as the material is not in poor condition and it remains nonfriable during all phases of removal, handling, and waste disposal;
- ✓ Asbestos encapsulation (notification may be required by DLARA); and
- ✓ Removal of interior, non-load supporting walls that are not associated with any regulated asbestos-containing material.

### **ASBESTOS NESHAP ADVANCE NOTIFICATION REQUIREMENT**

An important aspect of the NESHAP is the advance notification requirement, which enables the AQD to ensure that all precautions are being taken to minimize asbestos emissions. Building **owners** or contractors must submit notifications for all subject demolitions and for subject renovations where the amount of RACM meets or exceeds the thresholds. Notifications should be entered online using our online Asbestos Notification System (ANS) found at [www.michigan.gov/air](http://www.michigan.gov/air) under "Asbestos NESHAP Program" at least ten **working days** prior to beginning regulated demolition or renovation activities. For planned renovation operations involving individual, nonscheduled operations, the notification is required at least ten working days before the beginning of the calendar year for which notice is being given. Notifications must be entered as early as possible, but not later than the following work day for ordered demolitions and for emergency renovation operations. An **emergency renovation operation** means that the renovation operation was not planned but results from a sudden, unexpected event that, if not immediately attended to, presents a safety or public health hazard, is necessary to protect equipment from damage, or is necessary to avoid imposing an unreasonable financial burden.

The notification must include the following information:

- ✓ Date of notification (or date of revision);
- ✓ Type of notification (original, revised, canceled, annual);
- ✓ Type of operation (demolition or renovation);
- ✓ Scheduled starting and completion dates of asbestos removal work;
- ✓ Scheduled starting and completion dates of demolition or renovation;
- ✓ Abatement contractor information;
- ✓ Demolition contractor information (if project is a demolition);
- ✓ Facility owner information;
- ✓ Facility description including location;
- ✓ Disposal site information;
- ✓ Waste transporter information;
- ✓ Ordered demolition information (if project is an ordered demolition);

## Understanding the Asbestos NESHAP

- ✓ Estimate of amount of RACM to be removed and amount of Category I and Category II nonfriable ACM that will not be removed before demolition;
- ✓ Project description, including surfaces asbestos will be removed from, removal method, and method of demolition;
- ✓ Engineering controls description;
- ✓ Procedure if unexpected asbestos is found;
- ✓ Procedure used to detect asbestos;
- ✓ Emergency renovation information (if project is an emergency renovation); and
- ✓ Certification that at least one trained person will supervise the asbestos stripping and removal.

Michigan's "Notification of Intent to Renovate/Demolish" form should be used to fulfill the notification requirement using the online ANS. For the online link, along with guidelines on how to complete the form, see the "Where to Get Additional Information" section on page 10. U.S. Postal Service, commercial delivery service, or hand delivery (or revisions to notifications) is not recommended. Telefaxing notifications is not acceptable. It is not necessary to send copies of NESHAP notifications to the U.S. EPA for renovation or demolition activities in Michigan.

### • **Revising a Notification**

A revised notification should be sent any time there is a change in any of the required information previously submitted. The NESHAP specifically requires a revision if the amount of asbestos reported changes by 20% (either a decreased amount or an increased amount). An increased amount refers to additional asbestos unexpectedly found while working on the specific project covered in the notification. If the scope of the project increases, a new notification is required. For example, removing asbestos from an area of the building not covered by the original notification would be considered a change in project scope.

### • **Revising Project Dates**

If the project will begin on a date later than the date in the original notice (or latest revision), revise the notification no later than the previously scheduled start date. If the project will start earlier than the original start date (or latest revision), provide the new start date at least ten working days before beginning the project. **Under no circumstances shall a NESHAP project begin on a date other than the date in the notification (or the latest revised notification).**

If a project will be postponed indefinitely and a new start date cannot be predicted immediately submit a revised notification canceling the project. If the project is rescheduled, a new notification must be submitted at least ten working days prior to beginning the project. It is unacceptable to indefinitely postpone a project and then submit a revised start date less than ten working days before the project is to begin.

## **WORK PRACTICE STANDARDS**

For a demolition project, the RACM is not required to be removed or stripped if any of the following criteria are met:

- ✓ It is Category I nonfriable ACM that is not in poor condition, is not **friable**, and a licensed asbestos abatement contractor is made available at the demolition site.
- ✓ It is on a **facility component** that is encased in concrete or other similarly hard material and is adequately wet whenever exposed during demolition.
- ✓ It was not accessible for testing and, therefore, was not discovered until after the demolition



## Understanding the Asbestos NESHAP

began and as a result of the demolition cannot be safely removed.

- ✓ It is Category II nonfriable ACM with low probability of becoming crumbled, pulverized, or reduced to powder during demolition.
- ✓ For large facility components (reactor vessels, large tanks, steam generators, etc. but not beams): the component is removed, transported, stored, disposed of, or reused without disturbing or damaging the RACM; the component is encased in a **leak-tight** wrapping; and the leak-tight wrapping is properly labeled during loading, unloading, and storage.

If a facility is demolished by intentional burning (e.g., fire training), all ACM including Category I and Category II nonfriable ACM is regulated and must be removed before burning.

Remove all RACM from a facility being demolished or renovated before any activity begins that would break up, dislodge, or similarly disturb the material. When stripping asbestos from a facility component while it remains in place in the facility, **adequately wet** the asbestos. After a facility component that is covered with asbestos is taken out of a facility, it shall be stripped or contained in leak-tight wrapping. When stripping, adequately wet the component or use a local exhaust ventilation and collection system designed and operated to capture the particulate asbestos material.

The following requirements must be followed for RACM, including material that has been removed or stripped:

- ✓ Adequately wet the material and ensure that it remains adequately wet until collected and contained or treated in preparation for disposal;
- ✓ Carefully lower the material to the ground and floor, not dropping, throwing, sliding, or otherwise damaging or disturbing the material; and
- ✓ Transport the material to the ground via leak-tight chutes or containers if it has been removed or stripped more than 50 feet above ground level and was not removed as units or in sections.

There are two situations for which the requirement for adequately wetting the material does not apply. The first case is when the temperature at the point of wetting is below 32° F. The temperature must be recorded at the beginning, middle, and end of each work day; and these records must be kept for two years. The second situation involves renovation operations where wetting would unavoidably damage equipment or present a safety hazard. For these operations, written approval must be obtained from DEQ (submit a request for a waiver for not wetting in writing to DEQ [address listed in "Where to Get Additional Information" section on page 10]), and the following emission control methods must be used:

- (1) A local exhaust ventilation and collection system designed and operated to capture the particulate asbestos material;
- (2) A glove-bag system designed and operated to contain the particulate asbestos material; and
- (3) Leak-tight wrapping to contain all RACM prior to dismantlement.

## **WASTE DISPOSAL**

The Asbestos NESHAP specifies that no **visible emissions** can be discharged to the outside air from the collection, processing, transport, and disposal of **asbestos-containing waste materials**. After wetting, seal all asbestos-containing waste material in leak-tight containers. If the waste will not fit into containers, it must be placed in leak-tight wrapping. Label the containers or wrapped materials being taken away from the facility using warning labels specified by the Occupational Safety and Health Administration (OSHA) and the U.S. DOT. The label should include the name of the **waste generator** and the location at which the waste was generated. Asbestos-containing waste materials must be deposited as soon as practical to an appropriate waste disposal site. Vehicles used to transport asbestos-containing waste materials must be marked during the loading and unloading of waste. U.S. DOT regulations require the proper identification number of "NA2212" be placed on shipping papers and package marking.

## Understanding the Asbestos NESHAP

Waste shipment records must be maintained by the owner or operator of a demolition/renovation operation. The following information is required on waste shipment records:

- ✓ Generator name, address, and telephone;
- ✓ Asbestos NESHAP program agency name and address;
- ✓ Quantity of asbestos-containing waste materials (cubic meters or cubic yards);
- ✓ A monitored emergency response telephone number for a person who is knowledgeable of the hazardous material being shipped and has comprehensive emergency response and incident mitigation information, or who has immediate access to a person with such knowledge;
- ✓ Waste disposal site operator name and telephone;
- ✓ Disposal site name and physical location;
- ✓ Transport date;
- ✓ Transporter name, address, and telephone; and
- ✓ Certification.

Provide a copy of the waste shipment record to the disposal site owner or operator at the time of delivery. If a copy of the waste shipment record signed by the owner or operator of the waste disposal site is not received by the waste generator within 35 days, contact the transporter and disposal site to determine the status of the waste shipment. Notify the AQD in writing if a signed waste shipment record is not received from the waste disposal site within 45 days. Keep a copy of all waste shipment records, including the signed copy, for at least two years.

Under Part 115 of Michigan Public Act 451 of 1994, as amended, administered by DEQ, all asbestos-containing material regulated by any state or federal regulations must be disposed of at a Type II (municipal solid waste) landfill. Asbestos-containing material that is nonfriable AND is not in poor condition or will not become friable at any time can be disposed of in a Type III (construction and demolition) landfill. Contact your local DEQ District Office or the Environmental Assistance Center (800-662-9278) if you have waste disposal questions.

### **TRAINING**

Training is required by three different federal and state agencies when it comes to the handling of asbestos, its removal, and the transportation of the material as a hazardous waste. The Asbestos NESHAP requires at least one trained supervisor to be present when asbestos-containing material is stripped, removed, disturbed, or otherwise handled. Evidence of this training must be posted and made available for inspection at the demolition or renovation site. In addition to training supervisors, the DLARA requires that asbestos workers receive training. For a list of certified trainers and/or for more information about DLARA training requirements, contact the DLARA Asbestos Program at 517-284-7680 or visit their website at [www.michigan.gov/asbestos](http://www.michigan.gov/asbestos). Finally, Hazmat employers are required to certify and document that Hazmat employees (as defined in 49 CFR 171.8) receive training in accordance with 49 CFR Part 172, Subpart H and Part 177. The training requirements would apply to any employee that transports asbestos, offers asbestos for transportation, prepares asbestos for transportation, or certifies a shipping paper or manifest for transportation. U.S. DOT training requirements cover such topics as general awareness/familiarization with 49 CFR Chapter I, Subchapter C; function-specific training for employees; safety methods and emergency response procedures; and security awareness training for risks associated with the transport of hazardous materials.

**WHY COMPLY WITH THE ASBESTOS NESHAP**

Compliance with the Asbestos NESHAP will reduce the public's and workers' exposure to asbestos and will keep facility owners and contractors operating within the law. Non-compliance with the NESHAP is a significant violation. The AQD attempts to reach a settlement with the owner and operator when violations of the Asbestos NESHAP occur. If a settlement acceptable to the U.S. EPA is not reached in a timely manner, the U.S. EPA may pursue enforcement action at the federal level. The U.S. EPA may decide to pursue an escalated enforcement action on its own. Violations of the NESHAP notification and work practice requirements may result in written warnings, administrative orders, civil penalties and/or criminal charges. Typically, violations are resolved with a consent order requiring the facility to pay a penalty and to comply with the regulations for all future demolitions or renovations. Some owners and operators who have knowingly violated the Asbestos NESHAP have been sentenced to prison terms.

**WHERE TO GET ADDITIONAL INFORMATION**

Additional information about asbestos is available on the Internet through the U.S. EPA's homepage ([www2.epa.gov/asbestos](http://www2.epa.gov/asbestos)). In addition, the Asbestos NESHAP notification form, guidelines for completing the form and regulations are located at [www.michigan.gov/air](http://www.michigan.gov/air). Select "Asbestos NESHAP Program". Questions about the federal OSHA standards or the state's asbestos compliance and training requirements can be obtained by visiting the DLARA Asbestos Program's web site at [www.michigan.gov/asbestos](http://www.michigan.gov/asbestos). Questions related to the transportation of asbestos can be addressed by the U.S. Department of Transportation's (U.S. DOT) Hazmat Information Center at 800-467-4922. You can also visit the U.S. DOT, Pipeline and Hazardous Materials Safety Administration's web site at <http://hazmat.dot.gov>.

• **Government Agency Contacts:**

**Michigan Department of Environmental Quality**

Air Quality Division – NESHAP Asbestos Program  
PO Box 30260  
Lansing, Michigan 48909-7760  
Notifications & General Asbestos Questions: 517-284-6777

**Michigan Department of Licensing and Regulatory Affairs**

MIOSHA Asbestos Program  
PO Box 30671  
Lansing, Michigan 48909-8171  
Main Line & General Asbestos Questions: 517-284-7680  
Accreditation, Training, Contractor Licensing: 517-284-7698  
Notifications: 517-284-7699

**Michigan State Police**

Commercial Vehicle Enforcement Division  
Hazardous Materials Unit  
PO Box 30634  
Lansing, Michigan 48913-0635  
517-241-0551

**U.S. Environmental Protection Agency**

Asbestos Program  
77 W. Jackson Boulevard  
Chicago, Illinois 60604  
Asbestos Hotline: 1-800-368-5888  
Environmental Hotline: 1-800-621-8431

## Understanding the Asbestos NESHAP

### ACRONYMS

ACM	Asbestos-Containing Material
AQD	Air Quality Division
CAA	Clean Air Act
C&E	Compliance and Enforcement
DEQ	Michigan Department of Environmental Quality
DLARA	Michigan Department of Licensing and Regulatory Affairs
NESHAP	National Emission Standards for Hazardous Air Pollutants
OSHA	Occupational Safety and Health Administration
PLM	Polarized Light Microscopy
RACM	Regulated Asbestos-Containing Material
U.S. DOT	U.S. Department of Transportation
U.S. EPA	U.S. Environmental Protection Agency

### DEFINITIONS

This section contains a list of definitions from the Asbestos NESHAP. Not all of these terms are used in this fact sheet.

**Active waste disposal site:** Any disposal site other than an inactive site.

**Adequately wet:** Sufficiently mix or penetrate with liquid to prevent the release of particulates. If visible emissions are observed coming from asbestos-containing material, then that material has not been adequately wetted. However, the absence of visible emissions is not sufficient evidence of being adequately wet.

**Asbestos:** The asbestiform varieties of serpentinite (chrysotile), riebeckite (crocidolite), cummingtonite-grunerite, anthophyllite, and actinolite-tremolite.

**Asbestos-containing materials:** Any materials containing more than 1% asbestos.

**Asbestos-containing waste materials:** Mill tailings or any waste that contains commercial asbestos and is generated by a source subject to the Asbestos NESHAP. This includes filters from control devices, friable asbestos waste material, and bags or other similar packaging contaminated with commercial asbestos. As applied to demolition and renovation operations, this term also includes regulated asbestos-containing material waste and materials contaminated with asbestos including disposable equipment and clothing.

**Asbestos mill:** Any facility engaged in converting, or in any intermediate step in converting, asbestos ore into commercial asbestos. Outside storage of asbestos material is not considered a part of the asbestos mill.

**Asbestos tailings:** Any solid waste that contains asbestos and is a product of asbestos mining or milling operations.

**Asbestos waste from control devices:** Any waste material that contains asbestos and is collected by a pollution control device.

**Category I nonfriable asbestos-containing material (ACM):** Asbestos-containing packings, gaskets, resilient floor covering, and asphalt roofing products containing more than 1% asbestos as determined using Polarized Light Microscopy.

**Category II nonfriable ACM:** Any material, excluding Category I nonfriable ACM, containing more than 1% asbestos as determined using Polarized Light Microscopy that, when dry, cannot be crumbled, pulverized, or reduced to powder by hand pressure.

**Commercial asbestos:** Any material containing asbestos that is extracted from ore and has value because of its asbestos content.

**Cutting:** To penetrate with a sharp-edged instrument and includes sawing, but does not include shearing, slicing, or punching.

## Understanding the Asbestos NESHAP

**Demolition:** The wrecking or taking out of any load-supporting structural member of a facility together with any related handling operations or the intentional burning of any facility.

**Emergency renovation operation:** A renovation operation that was not planned but results from a sudden, unexpected event that, if not immediately attended to, presents a safety or public health hazard, is necessary to protect equipment from damage, or is necessary to avoid imposing an unreasonable financial burden. This term includes operations necessitated by nonroutine failures of equipment.

**Fabricating:** Any processing (e.g., cutting, sawing, drilling) of a manufactured product that contains commercial asbestos, with the exception of processing at temporary sites (field fabricating) for the construction or restoration of facilities. In the case of friction products, fabricating includes bonding, debonding, grinding, sawing, drilling, or other similar operations performed as part of fabricating.

**Facility:** Any institutional, commercial, public, industrial, or residential structure, installation, or building (including any structure, installation, or building containing condominiums or individual dwelling units operated as a residential cooperative but excluding residential buildings having four or fewer dwelling units); any ship; and any active or inactive waste disposal site. For purposes of this definition, any building, structure, or installation that contains a loft used as a dwelling is not considered a residential structure, installation, or building. Any structure, installation, or building that was previously subject to the Asbestos NESHAP is not excluded, regardless of its current use or function.

**Facility component:** Any part of a facility including equipment.

**Friable asbestos material:** Any material containing more than 1% asbestos as determined using Polarized Light Microscopy, that when dry, can be crumbled, pulverized, or reduced to powder by hand pressure.

**Fugitive source:** Any source of emissions not controlled by an air pollution control device.

**Glove bag:** A sealed compartment with attached inner gloves used for the handling of asbestos-containing materials. Properly installed and used, glove bags provide a small work area enclosure typically used for small-scale asbestos stripping operations.

**Grinding:** To reduce to powder or small fragments and includes mechanical chipping or drilling.

**Hazmat employee:** Means a person who is employed by a hazmat employer and who, in the course of employment, directly affects hazardous materials transportation safety. This term includes an owner-operator of a motor vehicle which transports hazardous materials in commerce. This term includes an individual, including a self-employed individual, employed by a hazmat employer who, during the course of employment:

1. Loads, unloads, or handles hazardous materials;
2. Manufactures, tests, reconditions, repairs, modifies, marks, or otherwise represents containers, drums, or packagings as qualified for use in the transportation of hazardous materials;
3. Prepares hazardous materials for transportation;
4. Is responsible for safety of transporting hazardous materials; or
5. Operates a vehicle used to transport hazardous materials.

**Hazmat employer:** Means a person who uses one or more employees in connection with: transporting hazardous materials in commerce; causing hazardous materials to be transported or shipped in commerce; or representing, marking, certifying, selling, offering, manufacturing, reconditioning, testing, repairing, or modifying containers, drums, or packagings as qualified for use in the transportation of hazardous materials. This term includes an owner-operator of a motor

## Understanding the Asbestos NESHAP

vehicle which transports hazardous materials in commerce. This term also includes any department, agency, or instrumentality of the United States, a state, a political subdivision of a state, or an Indian tribe engaged in an activity described in the first sentence of this definition.

**In poor condition:** The binding or the material is losing its integrity as indicated by peeling, cracking, or crumbling of the material.

**Inactive waste disposal site:** Any disposal site or portion of it where additional asbestos-containing waste material has not been deposited within the past year.

**Installation:** Any building or structure or any group of buildings or structures at a single demolition or renovation site that is under the control of the same owner or operator (or owner or operator under common control).

**Leak-tight:** Solids or liquids cannot escape or spill out. It also means dust-tight.

**Malfunction:** Any sudden and unavoidable failure of air pollution control equipment or process equipment or of a process to operate in a normal or usual manner so that emissions of asbestos are increased. Failures of equipment shall not be considered malfunctions if they are caused in any way by poor maintenance, careless operation, or any other preventable upset conditions, equipment breakdown, or process failure.

**Manufacturing:** The combining of commercial asbestos—or, in the case of woven friction products, the combining of textiles containing commercial asbestos—with any other material(s), including commercial asbestos, and the processing of this combination into a product. Chlorine production is considered a part of manufacturing.

**Natural barrier:** A natural object that effectively precludes or deters access. Natural barriers include physical objects such as cliffs, lakes or other large bodies of water, deep and wide ravines, and mountains. Remoteness by itself is not a natural barrier.

**Nonfriable asbestos-containing material:** Any material containing more than 1% asbestos as determined using Polarized Light Microscopy, that, when dry, cannot be crumbled, pulverized, or reduced to powder by hand pressure.

**Nonscheduled renovation operation:** A renovation operation necessitated by the routine failure of equipment, which is expected to occur within a given period based on past operating experience but for which an exact date cannot be predicted.

**Outside air:** The air outside buildings and structures, including, but not limited to, the air under a bridge or in an open air ferry dock.

**Owner or operator of a demolition or renovation activity:** Any person who owns, leases, operates, controls, or supervises the facility being demolished or renovated or any person who owns, leases, operates, controls, or supervises the demolition or renovation operation, or both.

**Particulate asbestos material:** Finely divided particles of asbestos or material containing asbestos.

**Planned renovation operations:** A renovation operation, or a number of such operations, in which some RACM will be removed or stripped within a given period of time and that can be predicted. Individual, nonscheduled operations are included if a number of such operations can be predicted to occur during a given period of time based on operating experience.

**Regulated asbestos-containing material (RACM):** Any all of following: (a) friable asbestos material, (b) Category I nonfriable ACM that has become friable, (c) Category I nonfriable ACM that will be or has been subjected to sanding, grinding, cutting, or abrading, or (d) Category II nonfriable ACM that has a high probability of becoming or has become crumbled, pulverized, or reduced to powder by the forces expected to act on the material in the course of demolition or renovation operations.

## Understanding the Asbestos NESHAP

**Remove:** To take out RACM or facility components that contain or are covered with RACM from any facility.

**Renovation:** Altering a facility or one or more facility components in any way, including the stripping or removal of RACM from a facility component. Operations in which load-supporting structural members are wrecked or taken out are demolitions.

**Resilient floor covering:** Asbestos-containing floor tile, including asphalt and vinyl floor tile and sheet vinyl floor covering containing more than 1% asbestos as determined using Polarized Light Microscopy.

**Roadways:** Surfaces on which vehicles travel. This term includes public and private highways, roads, streets, parking areas, and driveways.

**Strip:** To take off RACM from any part of a facility or facility components.

**Structural member:** Any load-supporting member of a facility, such as beams and load supporting walls, or any nonload-supporting member, such as ceilings and nonload-supporting walls.

**Visible emissions:** Any emissions, which are visually detectable without the aid of instruments, coming from RACM or asbestos-containing waste material, or from any asbestos milling, manufacturing, or fabricating operation. This does not include condensed, uncombined water vapor.

**Waste generator:** Any owner or operator of a source covered by the Asbestos NESHAP whose act or process produces asbestos-containing waste material.

**Waste shipment record:** The shipping document, required to be originated and signed by the waste generator, used to track and substantiate the disposition of asbestos-containing waste material.

**Working day:** Monday through Friday including holidays that fall on any of the days Monday through Friday.



[LARA](#) / [MI OCCUPATIONAL SAFETY & HEALTH ADMINISTRATION](#) / [COMPLIANCE](#) / [ASBESTOS PROGRAM](#)

## Notifications



### Michigan Occupational Safety and Health Administration *ASBESTOS PROGRAM*

Contractors performing friable asbestos removal or encapsulation work in Michigan must provide project notifications indicating the starting/ending dates and other job-related information to the Asbestos Program within a specified time frame. The Asbestos Program requires project notification 10 days prior to any non-emergency asbestos abatement project exceeding 10 linear feet or 15 square feet, or both, of friable asbestos-containing materials. A one-percent (1%) project notification fee must also be included. Emergency asbestos abatement projects require notification by phone, fax, or mail prior to starting the projects. Please call for approval and instructions on what can be considered emergency situations.

In Michigan, the Air Quality Division (AQD) of the Department of Environmental Quality (DEQ) has been delegated to implement the National Emission Standards for Hazardous Air Pollutants (NESHAP) program for asbestos. The asbestos NESHAP protects the public and environment by minimizing the release of asbestos fibers during renovation and demolition activities. Advanced notification is required to ensure all precautions are being taken to minimize asbestos emissions. Project notifications may also be required by the DEQ. Please contact DEQ at 517-241-7463 for the NESHAP notification requirements.

[Search for a Scheduled Project Notification](#)

[Notification Form \(doc / pdf\)](#)

This Notification Form has been designed to print and mail to the MIOSHA Asbestos Program or DEQ. This form has been developed in Microsoft Word as a template and as a PDF. The information typed on the WORD form can be saved and revised as needed. However, it IS NOT designed to be submitted electronically.

[Asbestos Program Home](#) | [Contact Us](#)





# NOTIFICATION OF INTENT TO RENOVATE/DEMOLISH



MICHIGAN DEPARTMENT OF ENVIRONMENTAL QUALITY  
(MDEQ) AIR QUALITY DIVISION  
NESHAP, 40 CFR Part 61, Subpart M



MICHIGAN DEPARTMENT OF LICENSING AND  
REGULATORY AFFAIRS (LARA), ASBESTOS PROGRAM,  
P.A. 135 OF 1986, AS AMENDED, Section 220 (1-4) or (8)

### DEQ/LARA USE ONLY

Postmark Date \_\_\_\_/\_\_\_\_/\_\_\_\_ Rec'd Date \_\_\_\_/\_\_\_\_/\_\_\_\_  
 Emergency Date \_\_\_\_/\_\_\_\_/\_\_\_\_ Valid No. \_\_\_\_\_  
 OK     Send Def Ltr.    Date of Def Ltr. \_\_\_\_/\_\_\_\_/\_\_\_\_  
 FOLLOW UP \_\_\_\_/\_\_\_\_/\_\_\_\_ Spoke w/ \_\_\_\_\_  
 Comments: \_\_\_\_\_  
 \_\_\_\_\_  
 \_\_\_\_\_  
 \_\_\_\_\_  
 Notification No. \_\_\_\_\_ Trans No. \_\_\_\_\_

**Calculate LARA Asbestos Project Fee:** (1% Project Fee)  
 Total Project Cost: \_\_\_\_\_ x 0.01 = \_\_\_\_\_  
 Type of Contractor: \_\_\_\_\_ License No.: \_\_\_\_\_  
 Licensing Authority: \_\_\_\_\_

**1. NOTIFICATION:**  
 Date of Notification: \_\_\_\_\_  
 Date of Revision(s): \_\_\_\_\_  
 Notification Type:  Original     Revised     Canceled     Annual  
**Mark appropriate boxes: (both DEQ and LARA may apply):**  
**DEQ (NESHAP) [260 ln. ft./160 sq. ft. or more is threshold]**  
 Planned Renovation – 10 **working** days notice  
 Emergency Renovation  
 Scheduled Demolition – 10 **working** days notice  
 Intentional Burn – 10 **working** days notice  
 Ordered Demolition  
**LARA (MIOSHA) [Will not accept annual notifications]**  
 Demo, Reno, Encap. (>10 ln. ft./15 sq. ft.) 10 **calendar** days notice  
 Emergency Renovation/Encapsulation

**2. PROJECT SCHEDULE:**

	START DATE	END DATE
* Renovation	_____	_____
+Asb. Removal	_____	_____
+Demolition:	_____	_____
Encapsulation:	_____	_____

**Work Schedule:** Please indicate the anticipated days of the week and work hours for the purpose of scheduling a compliance inspection.

	Days of the Week	Work Hours
Asb. Removal:	_____	_____
Demolition:	_____	_____
Encapsulation:	_____	_____

\* Includes setup, build enclosure, asbestos removal, demobilizing, etc.  
 +Include **only** those dates you are conducting asbestos removal/demo.  
 Check here if this is a multi-phased project, attach a schedule showing the start/end date of each phase.

**3. ABATEMENT CONTRACTOR:** Internal Project #: \_\_\_\_\_  
 Name: \_\_\_\_\_  
 Mailing Address: \_\_\_\_\_  
 City/State/Zip: \_\_\_\_\_  
 E-mail: \_\_\_\_\_  
 Contact: \_\_\_\_\_ Phone: \_\_\_\_\_

**4. DEMOLITION CONTRACTOR:** Internal Project #: \_\_\_\_\_  
 Name: \_\_\_\_\_  
 Mailing Address: \_\_\_\_\_  
 City/State/Zip: \_\_\_\_\_  
 E-mail: \_\_\_\_\_  
 Contact: \_\_\_\_\_ Phone: \_\_\_\_\_

**5. FACILITY OWNER:** ("Facility" includes Bridges)  
 Name: \_\_\_\_\_  
 Mailing Address: \_\_\_\_\_  
 City/State/Zip: \_\_\_\_\_  
 E-mail: \_\_\_\_\_  
 Contact: \_\_\_\_\_ Phone: \_\_\_\_\_

**6. FACILITY DESCRIPTION:**  
 Facility Name: \_\_\_\_\_  
 Location Address/Description: \_\_\_\_\_  
 \_\_\_\_\_ If Apt. # of units: \_\_\_\_\_  
 City/Twp. \_\_\_\_\_ State: \_\_\_\_\_ Zip Code: \_\_\_\_\_  
 County: \_\_\_\_\_ Nearest Crossroad: \_\_\_\_\_  
 Size: (sq. ft.) \_\_\_\_\_ No. of Floors: \_\_\_\_\_ Floor No.: \_\_\_\_\_  
 Age: \_\_\_\_\_ Present Use: \_\_\_\_\_ Prior Use: \_\_\_\_\_  
 Specific Location(s) in Facility: \_\_\_\_\_

**7. DISPOSAL SITE:**  
 Name: \_\_\_\_\_  
 Location Address: \_\_\_\_\_  
 City/State/Zip: \_\_\_\_\_

8. WASTE TRANSPORTER 1:	WASTE TRANSPORTER 2:
Name: _____	_____
Address: _____	_____
City/State/Zip: _____	_____
Phone: _____	_____

**9. ORDERED DEMOLITIONS:** (See NESHAP regulations for definition of "Ordered Demolition.") A copy of the official Order must accompany this notification.  
 Gov't Agency Ordering Demo: \_\_\_\_\_  
 Name/Title of Person Signing Order: \_\_\_\_\_  
 \_\_\_\_\_  
 Date of Order: \_\_\_\_\_ Date Ordered to Begin: \_\_\_\_\_

**10. IS ASBESTOS PRESENT?**     Yes     No     To be removed prior to demolition

**Estimate the amount of asbestos:** Include RACM (Regulated Asbestos Containing Material) to be removed, encapsulated, etc. Also include the amount and type (floor tile, roofing, etc.) of non-friable Category I and/or Category II ACM that **will not** be removed prior to demolition. (**NOTE:** In a demolition, cementitious ACM **cannot** remain in a structure, as it is likely to become regulated in the demolition/handling process. It **must** be removed prior to demolition.)

RACM to be Removed	RACM to be Encapsulated	Non-friable ACM <b>not</b> removed prior to demo.		Units of Measure	
		Category I	Category II		
_____	_____	_____	_____	<input type="checkbox"/> Ln. Ft.	<input type="checkbox"/> Ln. M.
_____	_____	_____	_____	<input type="checkbox"/> Sq. Ft.	<input type="checkbox"/> Sq. M.
_____	_____	_____	_____	<input type="checkbox"/> Cu. Ft.*	<input type="checkbox"/> Cu. M.*

\*Volume (cubic ft./meters) should be used only if unable to measure by linear/square measure (example: asbestos has fallen off of surface).

**NOTIFICATION OF INTENT TO RENOVATE/DEMOLISH (continued)**

**11. PROJECT DESCRIPTION:** Complete **A) for Renovation** (asbestos removal/encapsulation) and/or **B) for Demolition**:

**A) RENOVATION:** Mark all surfaces/types of RACM to be removed:

- Piping     Fittings     Boiler(s)     Tanks(s)  
 Beam(s)     Duct(s)     Tunnel(s)     Ceiling Tile(s)  
 Mag Block     Other (describe) \_\_\_\_\_

**Encapsulation (for LARA):** Mark surfaces/types to be encapsulated:

- Piping     Fittings     Boiler(s)     Tank(s)  
 Beam(s)     Duct(s)     Tunnel(s)     Ceiling Tile(s)  
 Other (describe) \_\_\_\_\_

**Method of removal:** Describe how the asbestos will be removed from the surface (example: glove bag, scrape with hand tools, cut in sections and carefully lower, etc.): \_\_\_\_\_  
 \_\_\_\_\_

**B) DEMOLITION:** Describe the method of demolition of facility, bridge, etc., and indicate if complete or partial. If partial, describe which part of facility bridge, etc., will be demolished: \_\_\_\_\_  
 \_\_\_\_\_

**12. ENGINEERING CONTROLS:** Describe work practices and engineering controls used to prevent visible emissions before, during, and after removal, and until proper disposal: \_\_\_\_\_  
 \_\_\_\_\_

**13. UNEXPECTED ASBESTOS:** Describe the steps you intend to follow in the event that unexpected RACM is found or previously non-friable asbestos becomes friable (crumbled, pulverized, reduced to powder, etc.) and therefore regulated: \_\_\_\_\_  
 \_\_\_\_\_

**14. PROCEDURE(S) USED TO DETECT THE PRESENCE OF ASBESTOS:** **A)** Indicate how you determined whether or not asbestos is in the facility. If analytical sampling was used, describe method of analysis. (The determination of the presence or absence of asbestos must be made prior to submitting a renovation/demolition notification.): \_\_\_\_\_  
 \_\_\_\_\_

**B)** Name, address, and phone number of company performing asbestos survey: \_\_\_\_\_

**C)** Name, accreditation number of inspector, and date of inspection: \_\_\_\_\_

**15. EMERGENCY RENOVATIONS:** Date/time of emergency: \_\_\_\_\_ Describe the sudden, unexpected event: \_\_\_\_\_  
 \_\_\_\_\_

Explain how the event caused unsafe conditions, and/or would cause equipment damage and/or an unreasonable financial burden: \_\_\_\_\_  
 \_\_\_\_\_

**16.** I certify that an individual trained in the provisions of 40 CFR Part 61, Subpart M, will be on-site during the renovation and during demolition involving RACM above the threshold and/or during an ordered demolition. Evidence that this person has completed the required training will be available for inspection at the renovation or demolition site.

\_\_\_\_\_  
*Signature of Owner or Abatement Contractor      Date*

\_\_\_\_\_  
*Signature of Owner or Demolition Contractor      Date*

**17. Signature Requirements for Projects with Negative Pressure Enclosures: (required by LARA)**  
**Per Section 221(1)(2) of P.A. 135 of 1986, as amended, clearance air monitoring is required for any asbestos abatement project involving 10 linear feet/15 square feet or more of friable material which is performed within a negative pressure enclosure. I (the building owner or lessee) have been advised by the contractor of my responsibility under Act 135 to have clearance air monitoring performed on this project.**

\_\_\_\_\_  
*Signature of Building Owner or Lessee      Date*

\_\_\_\_\_  
*Signature of Asbestos Abatement Contractor Representative      Date*

**NOTE:** It is not mandatory that a signed copy be sent to LARA unless requested. For affected projects, this section of the notification form must be completed, signed, and made part of your records before the project begins.

**18. I certify that the above information is correct:**

\_\_\_\_\_  
*Printed Name of Owner/Operator      Date*

\_\_\_\_\_  
*Signature of Owner/Operator      Date*

**MAILING ADDRESSES/PHONE NUMBERS:** (See Item 1 to determine which agency requirements/regulations are applicable to your project.)

For **Public Act 135 of 1986, as amended, Section 220 (1-4) or (8)**, mail to address below. For more info visit:  
<http://www.michigan.gov/asbestos>

MIOSHA Asbestos Program  
 LARA, CSHD  
 P.O. Box 30671  
 Lansing, MI 48909-8171

517.284.7699 (office), 517.284.7700 (fax)

For **NESHAP Demolitions/Renovations, 40 CFR, Part 61, Subpart M**, please use the e-submittal process. For more information visit <http://www.michigan.gov/air>, under Air Links click on Asbestos NESHAP Program.

NESHAP Asbestos Program  
 DEQ, AQD  
 P.O. Box 30260  
 Lansing, MI 48909-7760

517.284.6777 (Office)

Attachment:  
Inspection Procedures

## **Pre-Demolition Environmental Inspection Procedures**

### **HAZARDOUS MATERIALS INSPECTION**

Functional Spaces and dimensions are listed on **Table 1**. If obtained, representative photographs of for the above referenced property are included in **Attachment: Site Photographs**.

### **ASBESTOS CONTAINING BUILDING MATERIAL INSPECTION**

The property was inspected for the presence of asbestos-containing materials (ACMs) in order to meet the requirements of 40 CFR, Part 61, Subpart M, National Emissions Standards for Hazardous Air Pollutants (NESHAP).

#### **Asbestos Inspection**

The property was inspected for the presence of suspected ACMs. Typical building materials that may contain asbestos include drywall, plaster, stucco, floor tiles, roofing felt and shingles, ceiling tiles, insulation, pipe insulation, and duct insulation. Friable materials are defined as materials that when dry may be crumbled or reduced to powder using hand pressure and thus release asbestos fibers. For the purpose of this inspection friable and non-friable materials were identified and sampled.

#### **Sample Collection**

At least two samples of each suspected asbestos containing materials identified during the inspection was collected. For surfacing materials (sprayed and/or troweled on) a minimum of three samples were collected for areas that contained less than 1,000 square feet of the materials; five samples were collected for materials 1,000 to 5,000 square feet and seven samples were taken for areas greater than 5,000 square feet. A Michigan Accredited Asbestos Inspector collected representative samples of each suspected ACM. Each sample was placed into a sealed plastic bag and labeled. A description of the material and location of the sample collected was recorded in the field notes. The total quantity of each suspected ACM was estimated and recorded in the field notes.

### **Pre-Demolition Environmental Inspection Procedures**

A listing of suspect ACMs at this property that were sampled and sent to the laboratory for analysis is included in **Table 2**. A copy of a floor plan showing functional space locations is included in **Attachment: Site Drawing**. A copy of the *Notification of Intent to Renovate/Demolish* online form found on the Michigan Business One Stop via <http://www.michigan.gov/business>. A copy of the MDEQ instruction sheet is included in Attachment: **MDEQ Notification of Intent to Renovate/Demolish**.

### **Laboratory Analysis/Results**

Each sample of suspect ACM collected at this property was analyzed for asbestos content using polarized light microscopy (PLM) by a NVLAP and NIST accredited laboratory in accordance with 40 CFR Ch. I (1-1-87 Edition) Part 763, Subpart F, Appendix A, pp. 293-299. Asbestos containing materials are defined as materials that contain greater than one percent (>1%) asbestos. Each sample collected for analysis was delivered via USPS to APEX Research, Inc. 11054 Hi Tech Drive, Whitmore Lake, Michigan. Laboratory results are included in **Attachment: Laboratory Analytical Results.**

## LIMITATIONS

Limitations to this assessment include interior and exterior building finishes, poor lighting conditions, fire and structural damage in some instances, construction and household debris and flooded basements.

## SIGNATURE

This report was prepared based on the site conditions that existed at the time the inspection, sample collection, and the laboratory analytical results.

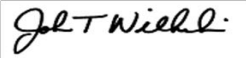
Prepared by:   
\_\_\_\_\_  
John Wilhelmi, Michigan Certified Asbestos Inspector  
Michigan Accreditation Number A40134

Reviewed by:

  
John A. Chacon, Jr.  
President